

INFRARED HEATING SYSTEM



SUPERIOR
RADIANT PRODUCTS

SERIES CV

CE 0085
UK
CA 0086



WARNING

Improper installation, adjustment, alteration, service, or maintenance can cause property damage, injury or death. Read the installation, operation, and service instructions thoroughly before installing or servicing this equipment.

FOR YOUR SAFETY

Do not store or use flammable vapors and liquids in the vicinity of this or any other appliance.

If you smell gas:

1. Open windows
2. Don't touch electrical switches
3. Extinguish any open flame
4. Immediately call your gas supplier

OWNER

Retain this Manual and ensure available for service. Improper installation, adjustment, alteration, service, or maintenance can cause injury, death or property damage.

Read the installation, operation, and service instructions thoroughly before installing or servicing this equipment

INSTALLER

Provide Manual to Owner upon completion of installation!

Read and thoroughly understand these Instructions before attempting any installation

Canada: 563 Barton Street, Stoney Creek, Ontario L8E 5S1

USA: 315 N Madison Street, Fortville, IN 46040

www.superiorradiant.com

CAUTION: FIRE OR EXPLOSION HAZARD

Maintain clearance to combustible materials as further specified in this manual. Failure to do so could result in a serious fire hazard. Heaters should not be located in hazardous atmospheres containing flammable vapors or combustible dusts. Signs should be provided in storage areas specifying maximum safe stacking height and safe parking locations for vehicles of various heights.

CAUTION: MECHANICAL HAZARD

This equipment expands and contracts with each operating cycle. The gas connection, suspension hardware, and the installation itself must safely allow this movement. Failure to do so could result in serious fire or explosion hazard.

CAUTION: FIRE OR EXPLOSION HAZARD

This heater is equipped with an automatic ignition device. Do not attempt to light the burner by hand. Failure to comply could result in a serious fire and personal injury hazard.

CAUTION: MECHANICAL HAZARD

Do not use high pressure (above $\frac{1}{2}$ psi [3.5 kPa]) to test the gas supply system with the burners connected. Failure to comply could result in damage to the burner and its control components requiring replacement.

CAUTION: SERVICE LIFE RISK

Do not install equipment in atmospheres containing halogenated hydrocarbons or other corrosive chemicals. Failure to comply may lead to premature equipment failure and invalidation of the warranty. Additionally, it is recommended that the equipment be installed with a slope downward and away from the burner of $\frac{1}{4}$ " in 10 ft (7 mm per 3 m) to allow drainage of start-up condensate.

CONTENTS

INTRODUCTION	5
CODES AND REGULATIONS	5
OPERATING PRINCIPLE	6
EQUIPMENT SPECIFICATIONS	7
SYSTEM LAYOUT TYPES.....	7
BASIC COMPONENTS.....	9
BURNERS	11
BURNER RATES	12
VACUUM PUMP EA	13
VACUUM PUMP EB	13
CLEARANCE TO COMBUSTIBLES	14
INSTALLATION	16
PREPARATION	16
LAYOUT LIMITS	16
ASSEMBLY OVERVIEW NOTES	18
1. RADIANT LINE SYSTEM	18
<i>A - Radiant Line Tubes</i>	19
<i>B - Tailpipe Tubes</i>	22
<i>C – Burners</i>	23
<i>D - Reflectors</i>	26
<i>E - Optional Shield Equipment</i>	29
<i>F - Deco-Grille Option</i>	34
2. VACUUM PUMP AND VENTING	35
<i>Vacuum Pump</i>	35
<i>Vacuum Pump Mounting</i>	35
<i>Venting</i>	37
<i>Ventilation Connections</i>	38
<i>Additional Pump Connections and Equipment</i>	39
3. OPTIONAL COMBUSTION AIR SUPPLY	39
<i>Combustion Air Supply Duct Connections</i>	40
4. GAS SUPPLY SYSTEM	41
<i>General Requirements</i>	41
<i>Flexible Gas Connector Line</i>	42
5. ELECTRICAL CONNECTIONS.....	42
<i>General Requirements</i>	42
<i>System Wiring Connections</i>	44
COMMISSIONING	47
1 - INSTALLATION CHECKLIST	47
2 - INITIAL SYSTEM POWER TEST	48
3 – COLD BALANCING THE SYSTEM VACUUM	48
4 – BURNER TIME DELAY SETTING	50
5 – BURNER ADJUSTMENT.....	51
6 – FINAL BALANCING THE SYSTEM VACUUM.....	53
OPERATION	54
MANUAL SET-UP	54
AUTOMATIC OPERATING SEQUENCE.....	54

<i>Start-up</i>	54
<i>Shut down</i>	54
MAINTENANCE	55
GENERAL SAFETY REMINDERS	55
ANNUAL MAINTENANCE RECOMMENDATIONS	55
<i>The System</i>	55
<i>Each Burner</i>	55
<i>Adjust the System</i>	56
<i>Burner adjustment</i>	56
TROUBLE-SHOOTING	57
VACUUM PUMP	57
BURNERS	57
PARTS	58
TECHNICAL DETAILS	62
TECHNICAL DETAILS – ERP DIRECTIVE	63
WARRANTY	64

INTRODUCTION

Superior Radiant Products is a company in the infrared heating industry founded on the principles of product quality and consumer commitment.

Quality commitment is evidenced by superior design, a regard for design detail and an upgrade of materials wherever justifiable.

Customer commitment is apparent through our ready responses to market demands and a never-ending training and service support program for and through our distributor network.

The Series CV, multi-burner gas-fired overhead radiant tube heater systems for non-domestic use, System H, is the culmination of decades of infrared expertise and commitment to quality products. The CV system is easy to install and maintain, offers flexibility of design which is unmatched in the industry and provides economical and trouble-free operation.

Important

These instructions, the layout drawing, local codes and ordinances, and applicable standards such as apply to gas piping and electrical wiring comprise the basic information needed to complete the installation and must be thoroughly understood along with general building codes before proceeding.

Only personnel who have been trained and understand all applicable codes should undertake the installation. SRP Representatives are Factory Certified in the service and application of this equipment and can be called on for helpful suggestions about installation.

Codes and Regulations

The CV system is designed and manufactured according to EN 777-4 "Multi-burner gas-fired overhead radiant tube heater systems for non-domestic use — Part 4: System H — Safety" and EN 416 "Single burner gas-fired overhead radiant tube heaters for non-domestic use".

This appliance must be installed in accordance with the rules in force. It shall be used in a space ventilated in accordance with the requirements of EN 13410 Gas-fired overhead radiant heaters - Ventilation requirements for non-domestic premises. Consult the instructions before installation and use of this appliance.

Every heater is subjected to a function test prior to leaving the factory and is pre-set for the relevant type of gas. The following regulations and directives are to be considered for the installation and operation of radiant heating systems.

EN 60335-1, Household and similar electrical appliances - Safety - Part 1: General requirements

EN 60335-2-102: Household and similar electrical appliances - Safety - Part 2-102: Particular requirements for gas, oil and solid-fuel burning appliances having electrical connections.

EN 12831, Heating systems in Buildings.

This heater is NOT approved for use in residential dwellings.

Operating Principle

The **CV System** operates on the following basic principles:

- The Burner Unit can provide Rates from **12 to 35 kW**.
- ONE Vacuum Setting is required for all Branches in the System and is independent of which Burner Model is installed.
- Individual Air Plates have been specially engineered to co-ordinate with the 'Position' a Burner is placed in on any Branch of the System.

Systems may be operated in the following mode:

- **Single Rate:** Entire system operates at ONE fixed Rate by setting the Vacuum Setting using Manual Dampers.
- **Modulating Rate:** Burner output Rates may be decreased from ideal designed rate by up to 40%.
 - o The use of Variable Frequency Drive which adjust the Vacuum Settings of all heaters in the system by adjusting the pump motor speed allowing the System to modulate.
 - o The use of Motorized Dampers which adjust the Vacuum Settings of individual Branches allows the System to modulate the overall Heat Output during operation to meet the building demand.

EQUIPMENT SPECIFICATIONS

System Layout Types

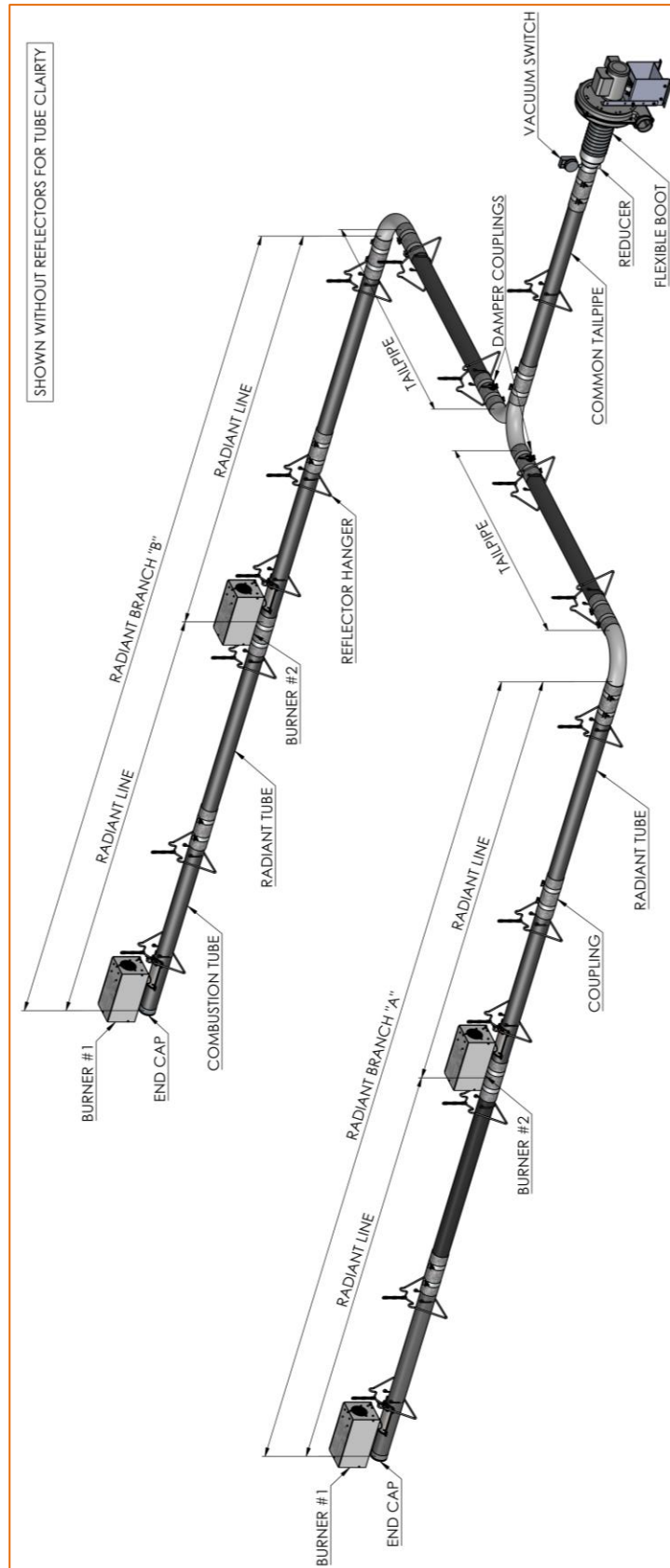

Figure 1: Symmetric System Overview

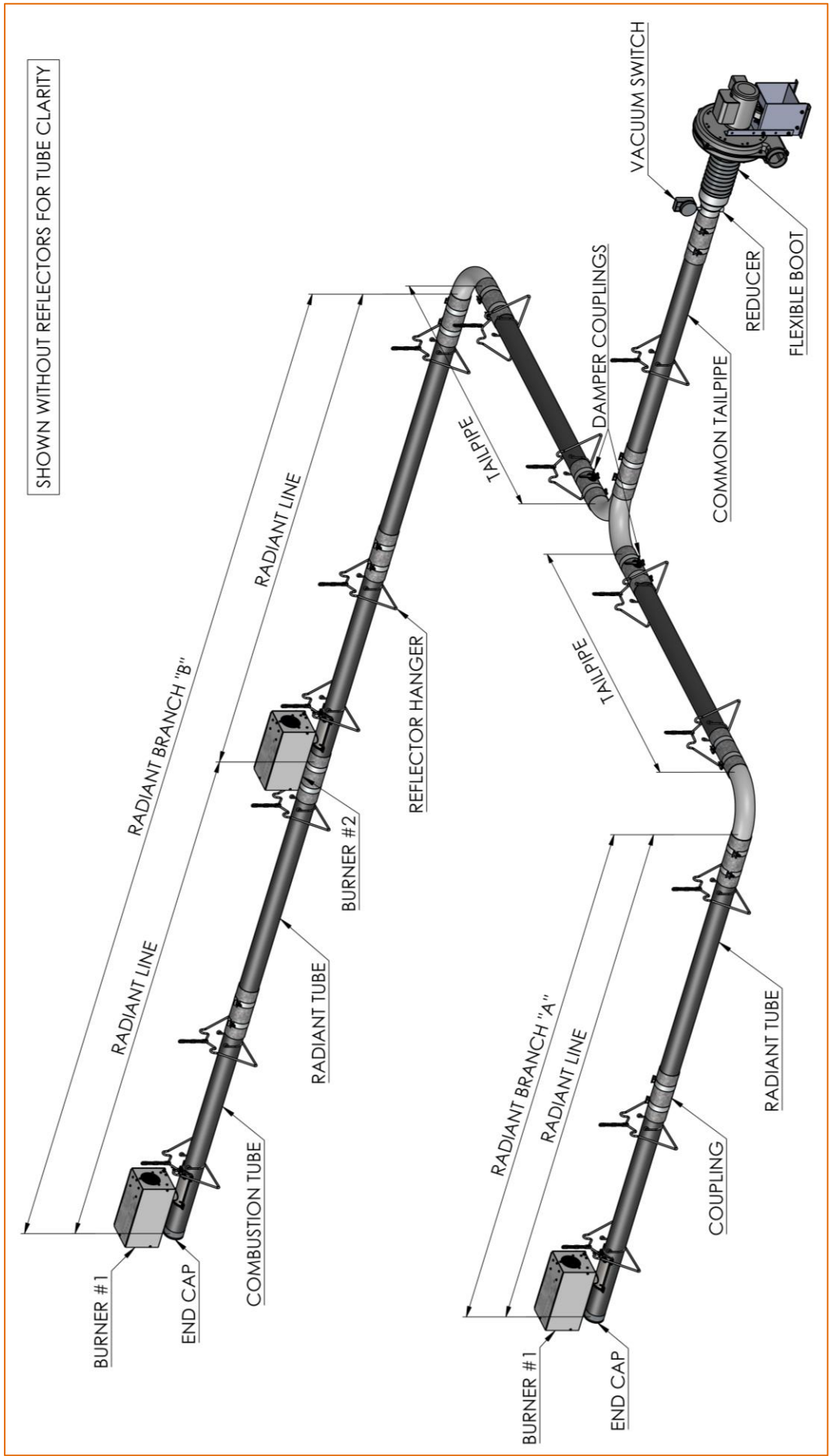

Figure 2: Non-Symmetric System Overview

Basic Components

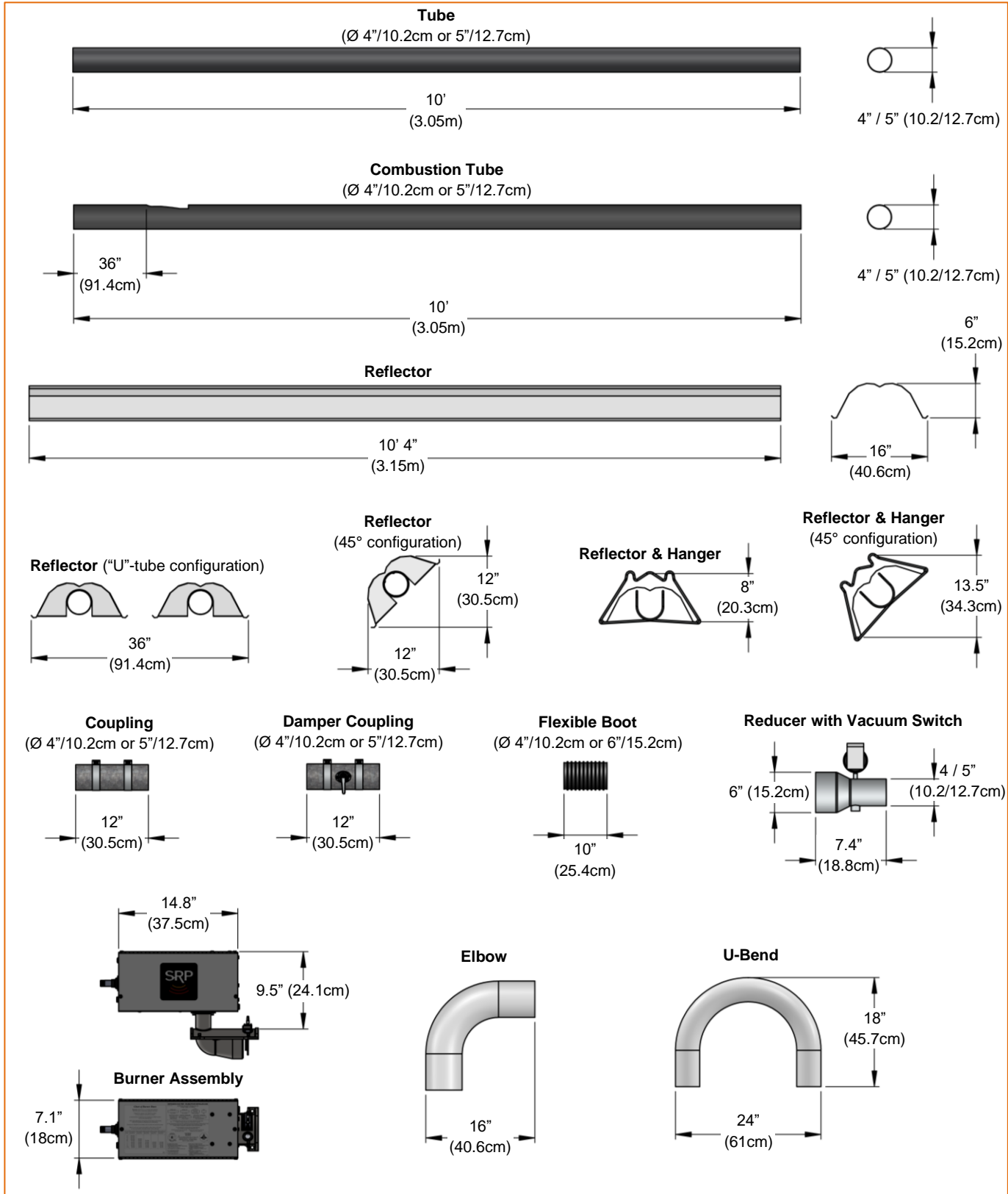

Figure 3: Common Component Dimensions

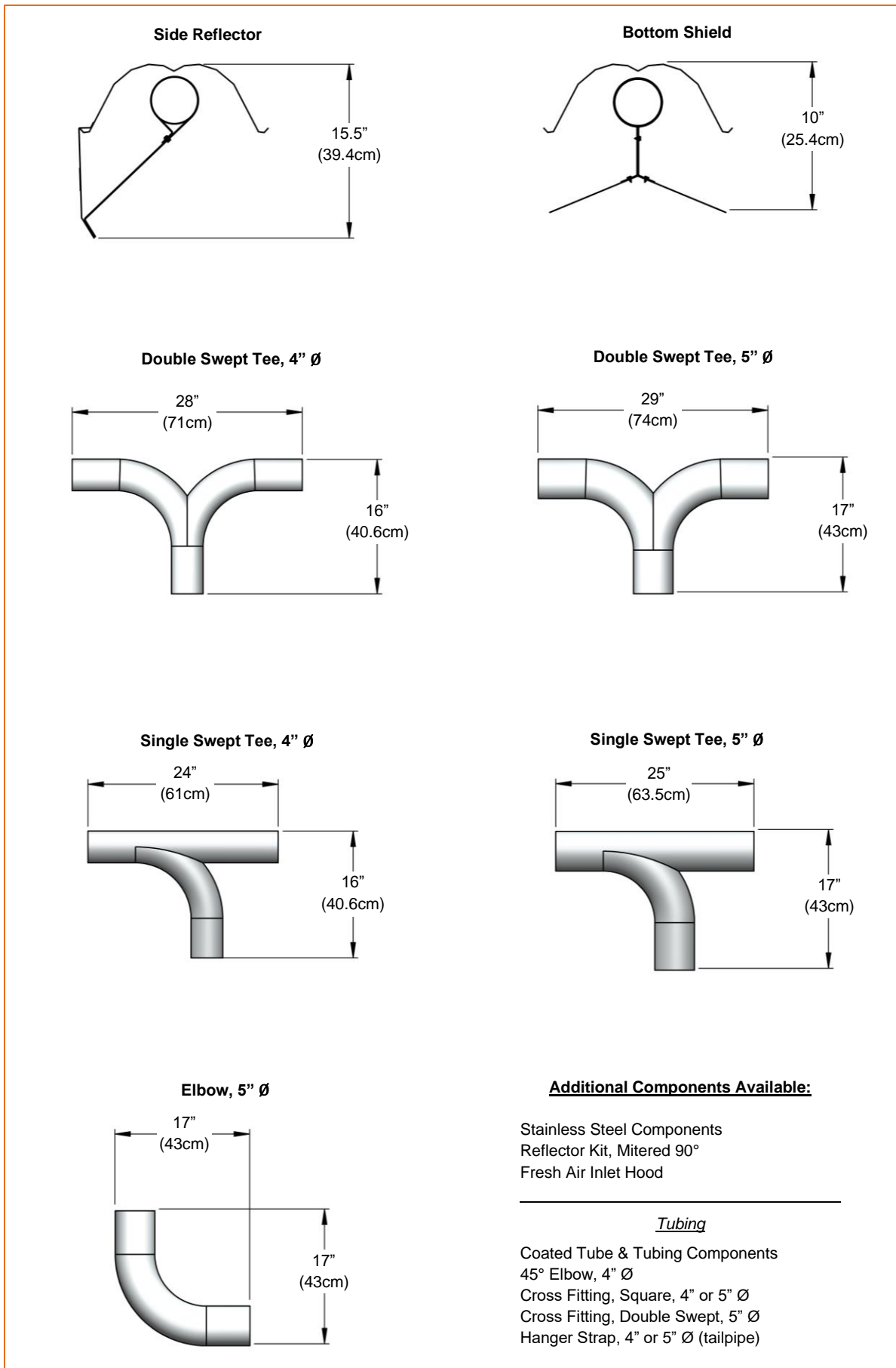

Figure 4: Specialty Component Dimensions

*A List of Parts and Part Numbers can be found in the PARTS Section at the end of this Manual.

Burners

General Burner Specifications

Supply Pressure

	Minimum	Nominal	Maximum
Natural Gas:	17.5 mbar	20 mbar	25 mbar

Manifold Pressure: Natural Gas: 0 mbar

Inlet Connection: 1/2" male BSP (adaptor supplied with burner box)

Electric Supply: Voltage 230 V, 50 Hz with L, N and PE Power consumption: 14 W

Flue and Outside Air Connection:
Flue Diameter: 100 mm Air inlet connection (optional): 100 mm

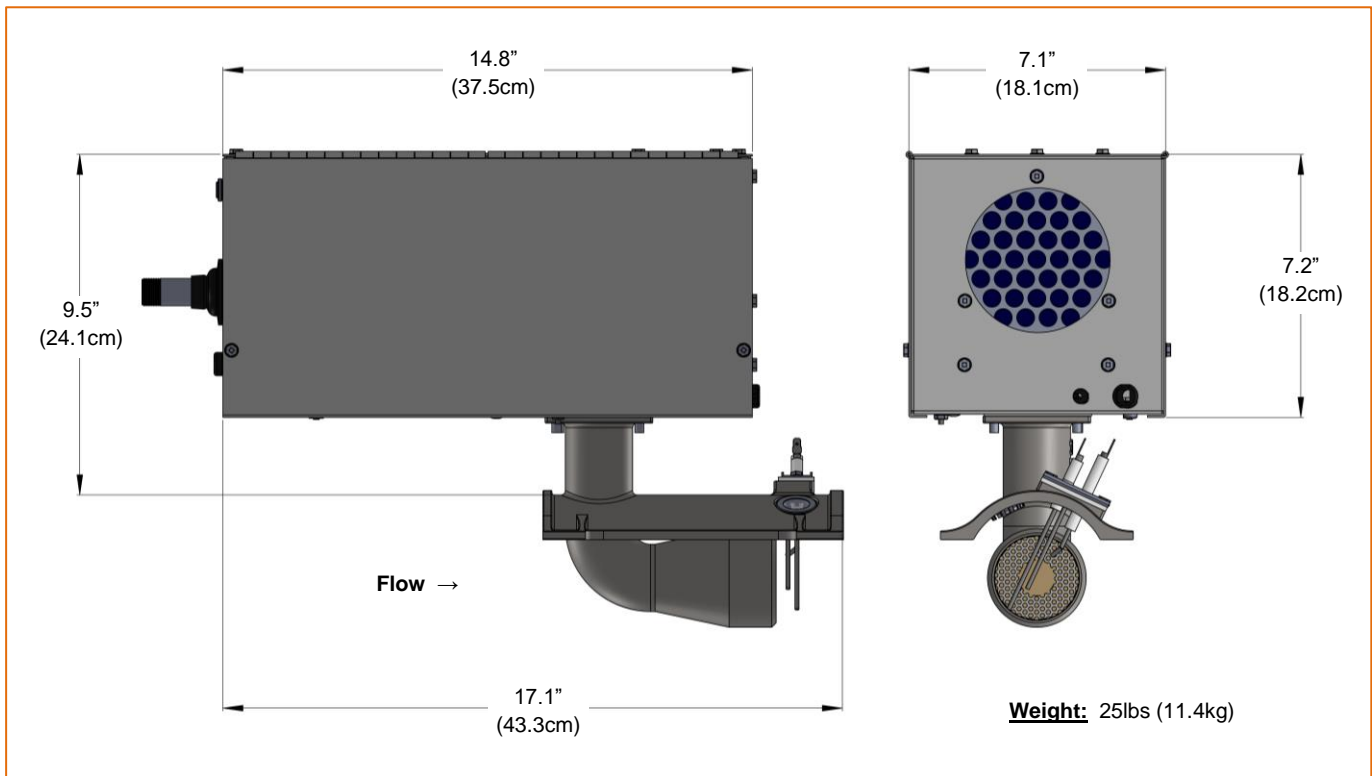

Figure 5: Burner Dimensions

BURNER RATES

Important: This burner is a variable input appliance.

See chart below to determine appliance burn rate.

Positions are identified in ascending order from the start end of the system.

A flow plate appropriate to the position of the burner in the system **MUST** be installed (see manufacturer's).

Note: An end vent vacuum intermediate to those shown will result in rates intermediate and proportional to those indicated.

Table A. CV Burner Rates (gross)

	Burner Position 1	Burner Position 2	Burner Position 3	Burner Position 4	Total per branch	Radiant Branch End Vent Vacuum	Burner Injector	
	kW	kW	kW	kW	kW	mbar	#	mm
CV 35	35	35	35		105	8.0	K	7.14
	35	35			70			
CV 32	32	32	32		96	7.0	K	7.14
	32	32			64			
CV 29	29	29	29	29	116	7.0	1	5.79
	29	29	29		87			
CV 23	23	23	23	23	92	7.0	13	4.70
	23	23	23		69			
CV 18	18	18	18	18	72	7.0	27	3.66
	18	18	18		54			
CV 12	12	12	12	12	48	7.0	31	3.05
	12	12	12		36			

Vacuum Pump EA

Electric Supply: 230/460 VAC, 50Hz, 3 PH, 0.75 HP

Tube Connection: 6" (15.2 cm) dia. Inlet & 4" (10.2 cm) dia. Outlet

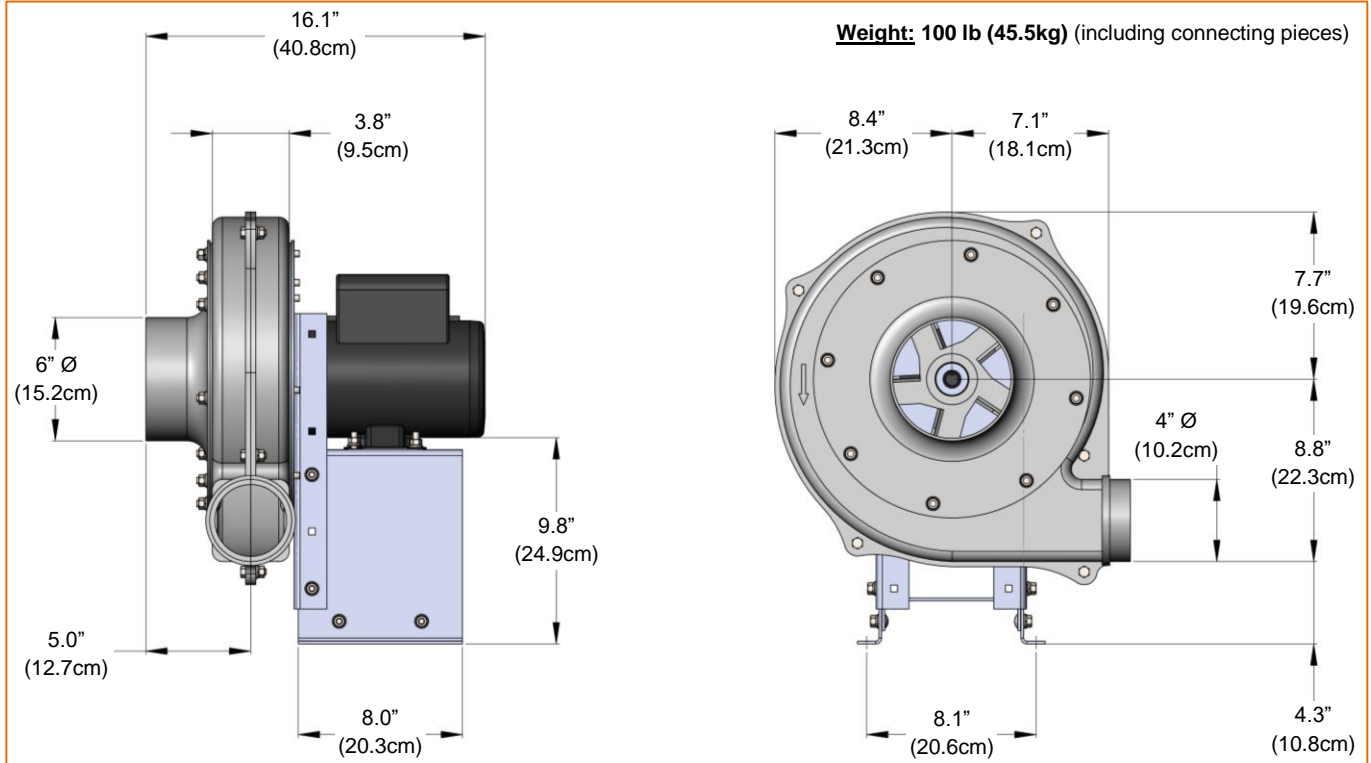

Figure 6: Vacuum Pump EA (Right-hand discharge configuration shown)

Vacuum Pump EB

Electric Supply: 230/460 VAC, 50 Hz, 3 PH, 1.5 HP

Tube Connection: 6" (15.2 cm) dia. Inlet & 6" (15.2 cm) dia. Outlet

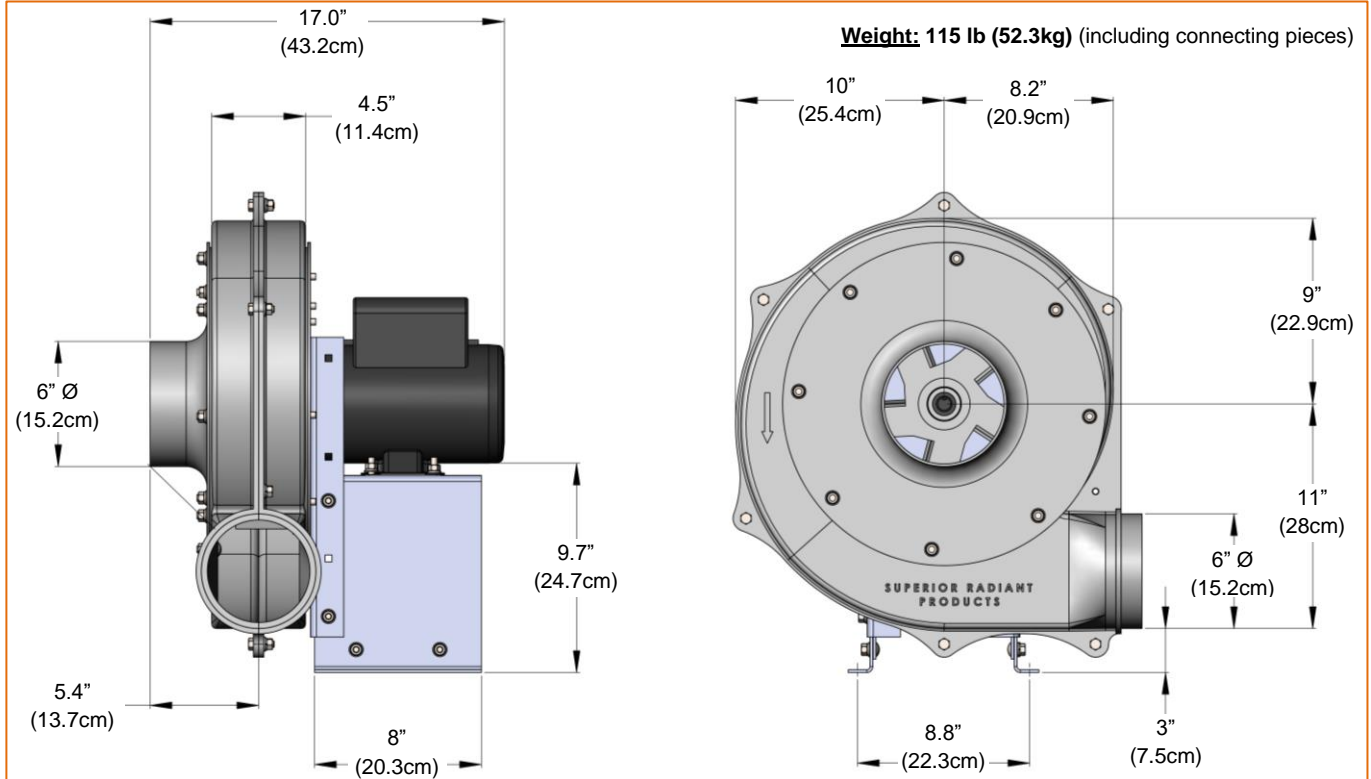

Figure 7: Vacuum Pump EB (Right-hand discharge configuration shown)

CLEARANCE TO COMBUSTIBLES

A general clearance of 500 mm in every direction is recommended for servicing around each Burner, Vacuum Pump, and End Vent Cap air supply (at the far end of each Radiant Branch) to ensure adequate air flow in and around the Heating System.

In addition to this it is very important to observe the minimum clearance to combustibles at all times to avoid any possibility of property damage or personal injury.

WARNING

- Clearances as marked on the heater body must be maintained from vehicles parked beneath. Signs should be posted identifying any possible violation of the clearance distances from the heater in all vehicle areas.
- Maximum allowable stacking height in storage areas should be identified with signs or appropriate markings adjacent to the thermostat or in a conspicuous location.

Table B lists the minimum clearance to combustible materials for various installation configurations. Note that standard clearances also apply to installation above T-bar ceilings and above decorative grills. Additional clearance may be required for glass, painted surfaces and other materials which may be damaged by radiant or convective heat.

Combustible materials are considered to be wood, compressed paper, plant fibres, plastics, Plexiglas or other materials capable of being ignited and burned. Such materials shall be considered combustible even though flame-proofed, fire-retardant treated or plastered.

Elbows and U-bends are un-heat-treated aluminized material and are typically installed without reflectors. Reflector miter kits are available for U-bends and elbows.

Adequate clearance to sprinkler heads must be maintained.

The stated clearance to combustibles represents a surface temperature of 50 °C above room temperature. Building materials with low heat tolerance (**such as plastics, vinyl siding, canvas, tri-ply, etc....**) maybe subject to degradation at lower temperatures. **It is the installer's responsibility to assure that adjacent materials are protected from degradation.**

Note 1:

Bottom Shields are approved for all burner sizes. The "below" clearance (dimension C in Table B) may be reduced by 25% when an approved Bottom Shield is used.

Note 2:

Reduced clearances downstream from the burner are approved for all configurations. Dimensions "B", "C", and "D" in Table B can be reduced for locations 7500 mm or more downstream from a burner, before the next burner by 50%.

Table B: Required Clearance to Combustibles

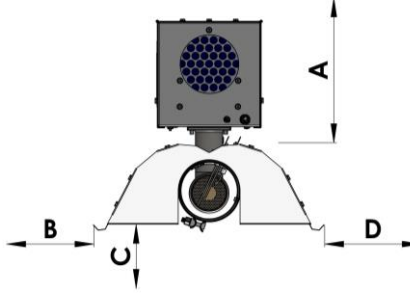
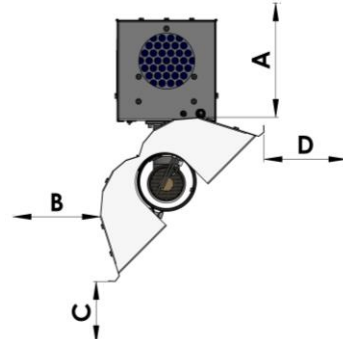
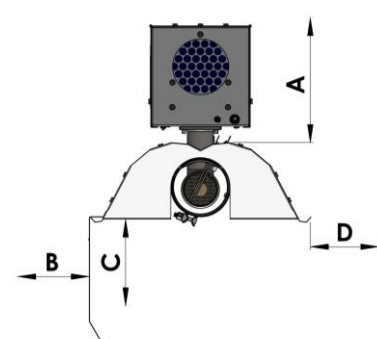
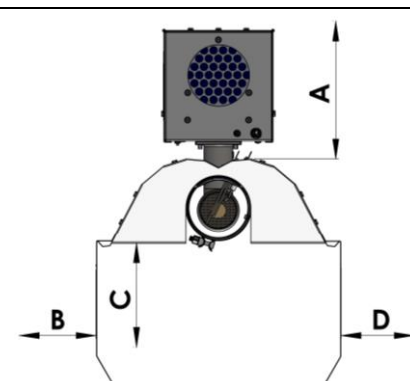
Reflector Configurations		Dimensions (mm)					
		CV 12	CV 18	CV 23	CV 29	CV 32	CV 35
	A	51	51	51	51	51	102
	B	381	381	432	584	711	762
	C	1143	1143	1270	1346	1473	1524
	D	381	381	432	584	711	762
	A	102	102	102	102	102	102
	B	102	102	102	102	102	102
	C	1016	1016	1219	1321	1524	1676
	D	965	965	1067	1168	1270	1499
	A	51	51	51	51	51	102
	B	102	102	102	102	102	102
	C	1270	1270	1422	1651	1778	1854
	D	813	813	864	965	1092	1245
	A	51	51	51	51	102	102
	B	229	229	356	406	457	533
	C	1270	1270	1422	1626	1803	1880
	D	229	229	356	406	457	533

*Clearance to combustibles for non-reflected fittings is 18" (500 mm).

INSTALLATION

Preparation

Most vacuum system designs are laid out on a clean blank sheet of paper. Unfortunately, typical construction does not permit this unimpeded access and therefore some planning and preparation early in the project will save much time and effort later on.

Start by reviewing the installation procedure. Examine where the equipment will be installed and how it will be supported. Please pay special attention to any objects that might be in the way or in close proximity to the heating system. Refer to Table B (Clearance to Combustibles) to ensure a safe distance between the heating system and any combustible materials.

Acquaint yourself with the standard components referred to in this manual. Many of these components are shown in detail in Figure 3. They are also shown in general assembly form in Figure 1 and Figure 2 to illustrate where the components fit in a typical symmetrical system and a non-symmetrical system. (These Figures are found in the Equipment Specifications section.)

If possible, lay the entire system out on the floor prior to installation. This will help identify any potential problems with the installation as well as any discrepancy in component quantity. Ensure that all Burners are those specified for the planned system in both output and gas type.

***DO NOT TRIM/CUT ANY Combustion Tube, adjust the System to fit around the Combustion Tubes**

Layout Limits

Ensure that the System Layout meets the limits required in Table C and Table D for the Burner Rate you intend the System to function at.

Table C: Radiant Tube System Layout Limits

	Burner Rating	Radiant Tube Lengths (Distance between Burners) (mm)			Minimum Distance to Elbow (mm)	
		Minimum	Recommended	Maximum	Before Burner	After Burner
CV 35	35	12192	15240	21336	950	6096
CV 32	32	12192	15240	21336	950	6096
CV 29	29	9144	12192	18288	950	4572
CV 23	23	6096	9144	13716	950	4572
CV 18	18	6096	7620	10668	950	4572
CV 12	12	4572	6096	7620	950	3048

*When minimum Radiant Tube lengths are used, minimum tailpipe length must be increased by 50%

Table D: Tailpipe Lengths Required for Various Branch Layouts

	Number of Burners in Branch	Burner Position 1	Burner Position 2	Burner Position 3	Burner Position 4	Total per branch	Minimum Tailpipe for Branch
		kW	kW	kW	kW	kW	mm
CV 35	3	35	35	35		105	18288
	2	35	35			70	15240
CV 32	3	32	32	32		96	18288
	2	32	32			64	15240
CV 29	4	29	29	29	29	116	18288
	3	29	29	29		87	18288
CV 23	4	23	23	23	23	92	18288
	3	23	23	23		69	12192
CV 18	4	18	18	18	18	72	12192
	3	18	18	18		54	12192
CV 12	4	12	12	12	12	48	9144
	3	12	12	12		36	9144

Exceptions:

- 1) When minimum Radiant Tube lengths are used, minimum tailpipe length must be increased by 50%
- 2) If using Common Tailpipe refer to the following to determine the Minimum Common Tailpipe length required:
 - 1 - Add up usual recommended lengths of Tailpipe (from data in this Table)
 - 2 - Subtract the length of any Tailpipe which will NOT be Common
 - 3 - If result is > 40' remaining, multiply by 0.6 for Minimum Common Tailpipe Length
 - OR 3 - If result is ≤ 40' remaining, multiply by 0.75 for Minimum Common Tailpipe Length
- 3) When using ≥ 5" (12.7cm) Ø Tailpipe, the Required Tailpipe Lengths may be reduced by 25%

Note: The configurations on Table D represent the minimum tailpipe lengths required to comply with safety and ErP requirements. The performance shown on the Technical Details at the end of this manual, is obtained when the tailpipe lengths are increased by 20%.

Assembly Overview Notes

Generally, there is no unique sequence for installation of the CV system. A review of the job site will often indicate a logical installation order. However, it is typical to start at the end of the branch with the furthest Burner location and continue that Branch downstream towards the Vacuum Pump, then begin again with the next Branch. Generally, 10 ft. (3050 mm) increments of Tube and Reflector can be used until one reaches the Common Tailpipe areas or Vacuum Pump connections. The general order of material in this manual is recommended for low-hassle installation purposes.

The Installation of the Entire System potentially consists of 5 individual Parts, one Part for each major component/system:

1. Radiant Line System, (Heat Exchangers)
2. Vacuum Pumps and Ventilation Systems,
3. Optional Combustion Air Supply System,
4. Gas Supply System, and
5. Electrical System(s)

Directions for the installation of each component/system are therefore found in the respective sections along with general information and safety notes as required.

1. Radiant Line System

For the purpose of this section the term “Radiant Line System” will refer only to the main heat exchanging components: Tubes, Burners, Reflectors, Tailpipes and attached Optional pieces. These must be hung from ceiling supports and form the main Radiant Lines and Branches of the Heat Exchanger System.

Installation of the Radiant Line System has been divided into 6 main parts as follows:

- Radiant Line Tubes
- Tailpipe Tubes
- Burners
- Reflectors
- Optional Shield Equipment
- Optional Deco-Grille

The order they are listed in is recommended for ease of installation and allows for adjustments to be made easily if required. Other orders of installation are possible; please note that there are certain components which, once installed, will make it more difficult to install others. Thoroughly read through the following installation directions for details on individual components.

Figure 8 illustrates the relationship of many of the various components of the Radiant Line System and will be a useful reference at many times during the installation.

NOTE: The CV System does not typically require the use of Baffles, if Baffles are desired please consult with the Manufacturer (SRP) prior to installation.

A - Radiant Line Tubes

All Combustion Tubes are heat-treated aluminized steel tubes. The remaining Radiant Tube length can be either hot rolled or heat-treated aluminized depending on the system design.

1. Locate hanging chain at predetermined points in the structure using methods as shown in Figure 9. The first 2 hanging points are approximately 7.5 ft. (2300 mm) apart to fully support each end of the first Tube. Thereafter spacing of 10 ft. (3050 mm) is acceptable, i.e. one hanging point per Tube. Ensure that Reflector Hangers located on a Combustion Tube are within 8" (200 mm) of the Burner. Ensure that the mounting height allows a downward slope of $\frac{1}{4}$ " per 10 ft. (7 mm per 3000 mm) towards the Vacuum Pump location.
2. Welded link chain with a working load limit of at least 500 lbs. (230 kg) is recommended. The suspension mechanism must allow for lateral expansion of the Tubing. A minimum length of 12" (300 mm) of hanging chain is recommended. Using turnbuckles between the chain and the Reflector Hanger allows for easy height adjustment later.

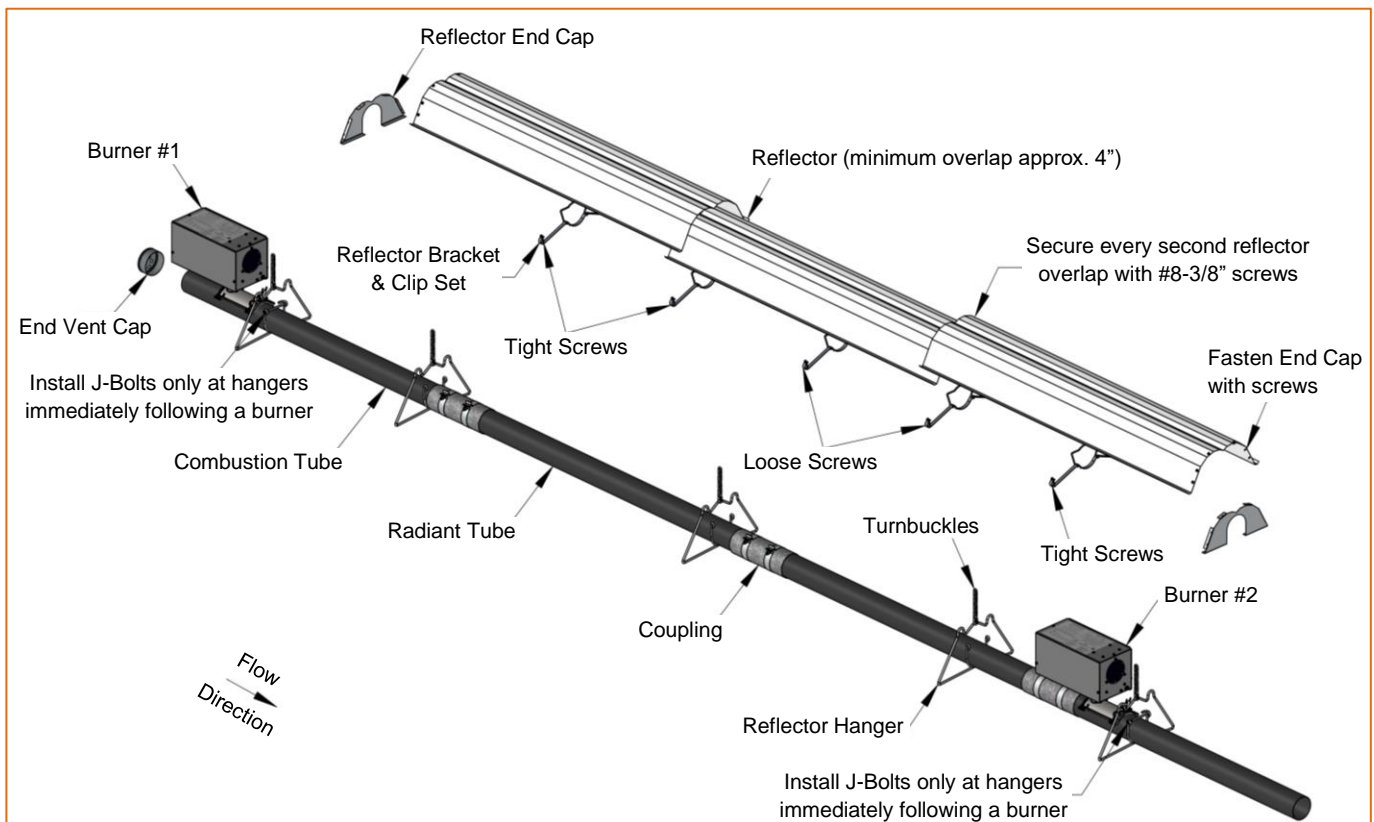

Figure 8: Radiant Line System - Component Relationships

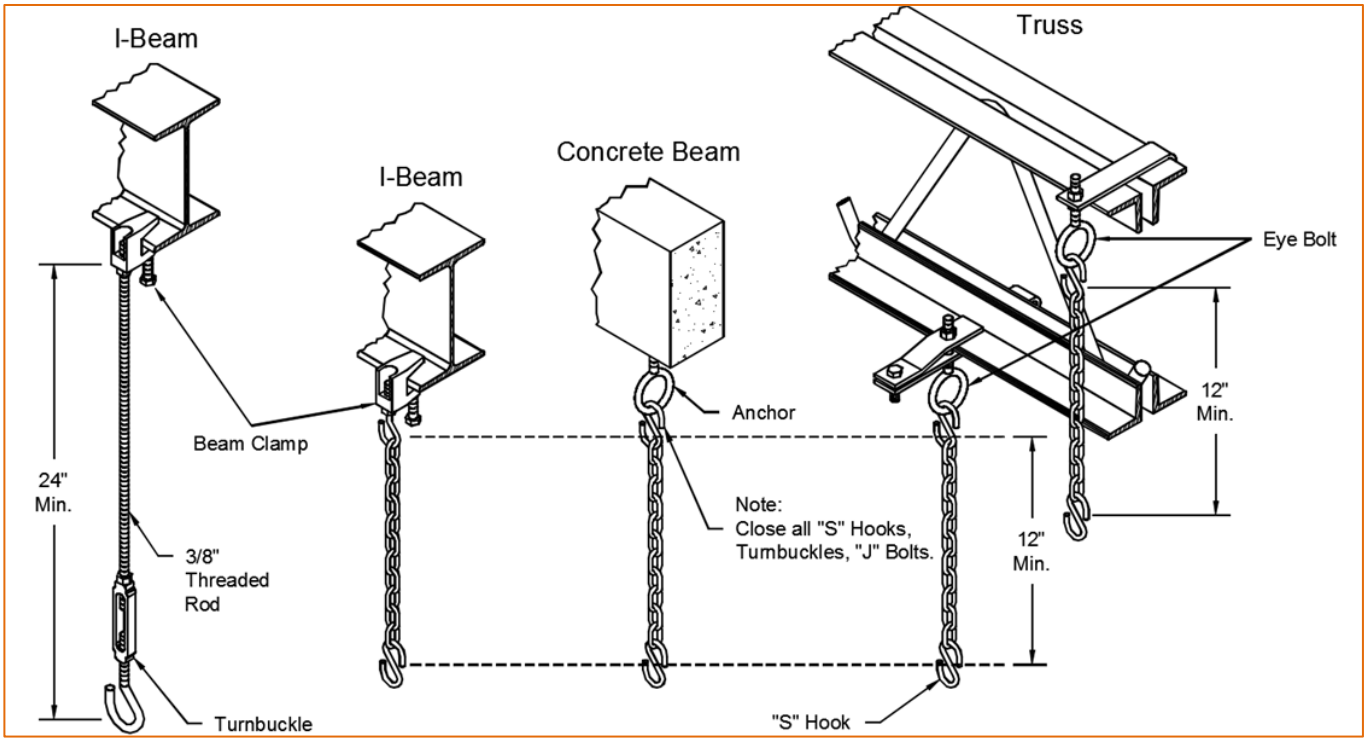

Figure 9: Ceiling Mounting/Hanging Options

3. Install an End Vent Cap at the beginning of each Branch (open end of the first Combustion Tube) and fasten it with a #8 x 3/8" screw as shown in Figure 10 below.

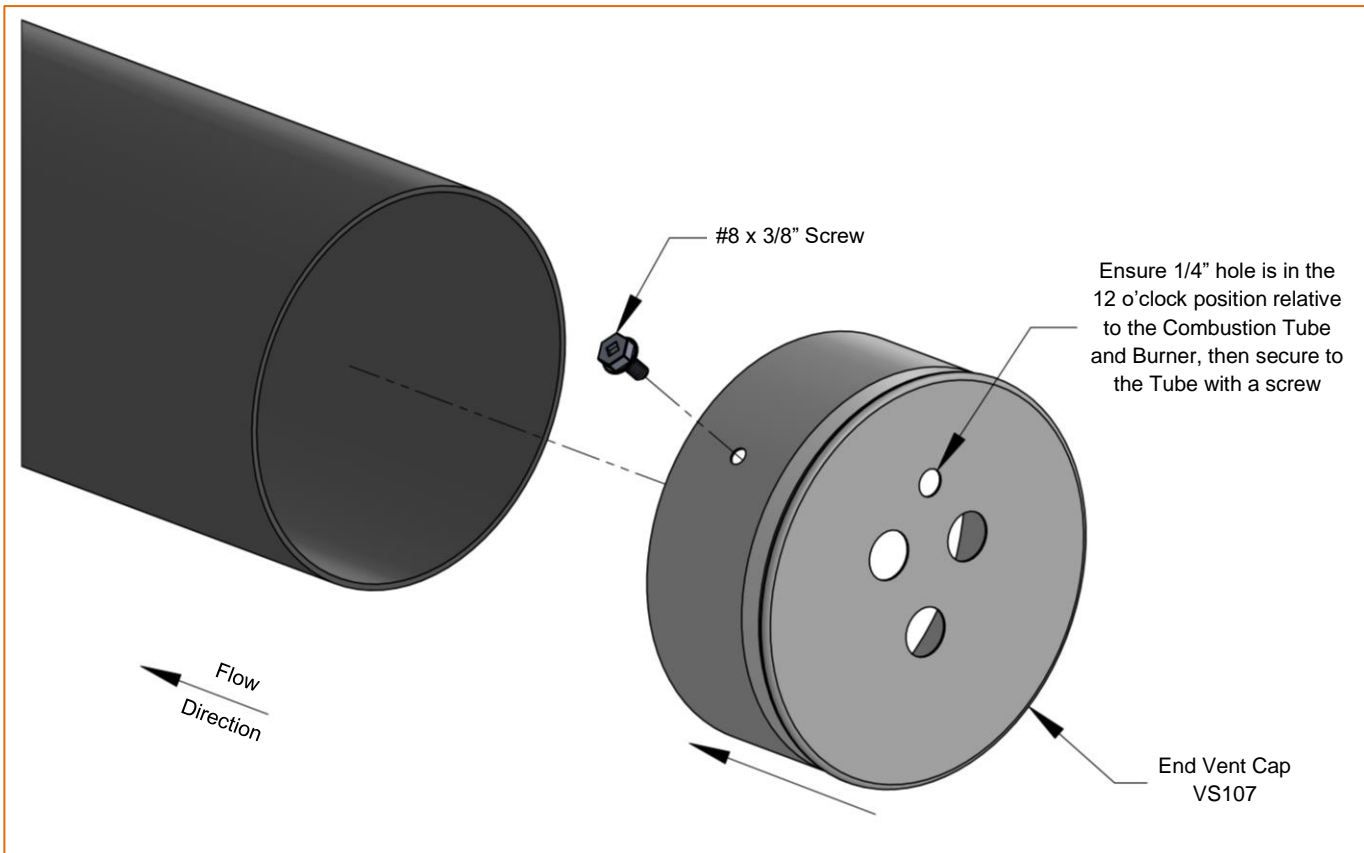

Figure 10: End Vent Cap Orientation

- Fasten the Reflector Hanger to the end of the hanging chain and place the Tube in the hanger. Ensure that Combustion Tubes have the Burner mounting hole positioned at 12 o'clock and facing downstream. (Refer to Figure 11).

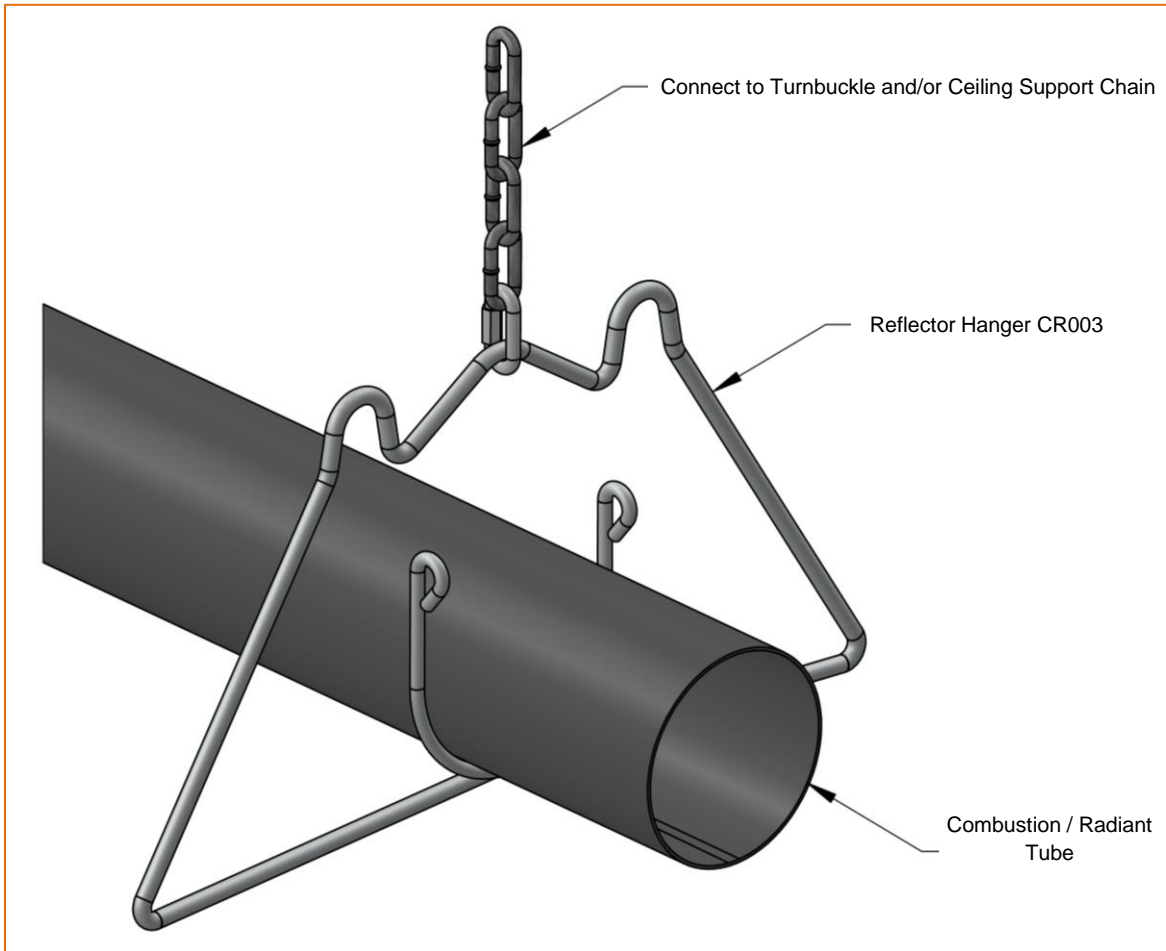

Figure 11: Tube and Reflector Hanger Detail

- Join consecutive pieces of Tube using Couplings. Insert one end of both Tubes fully into the Coupling. (Refer to Figure 12). These should be tightened as the Tubing is put in place, as it is more difficult to do so once the Reflector is installed. Tighten band clamps alternately to prevent buckling of the sleeve, set to Torque listed. Ensure that the weld seams on ALL Tubes are facing down.

Recommended Static Torque for Couplings		
	Stainless Steel	Aluminized
Nm	55 ± 8	70 ± 10
lb-ft	40 ± 6	51.6 ± 7

*Static (Audit) Torque is defined as the amount of torque required to rotate the nut approximately 1/8th turn in tightening direction immediately after rundown.

Figure 12: Tube Coupling Installation

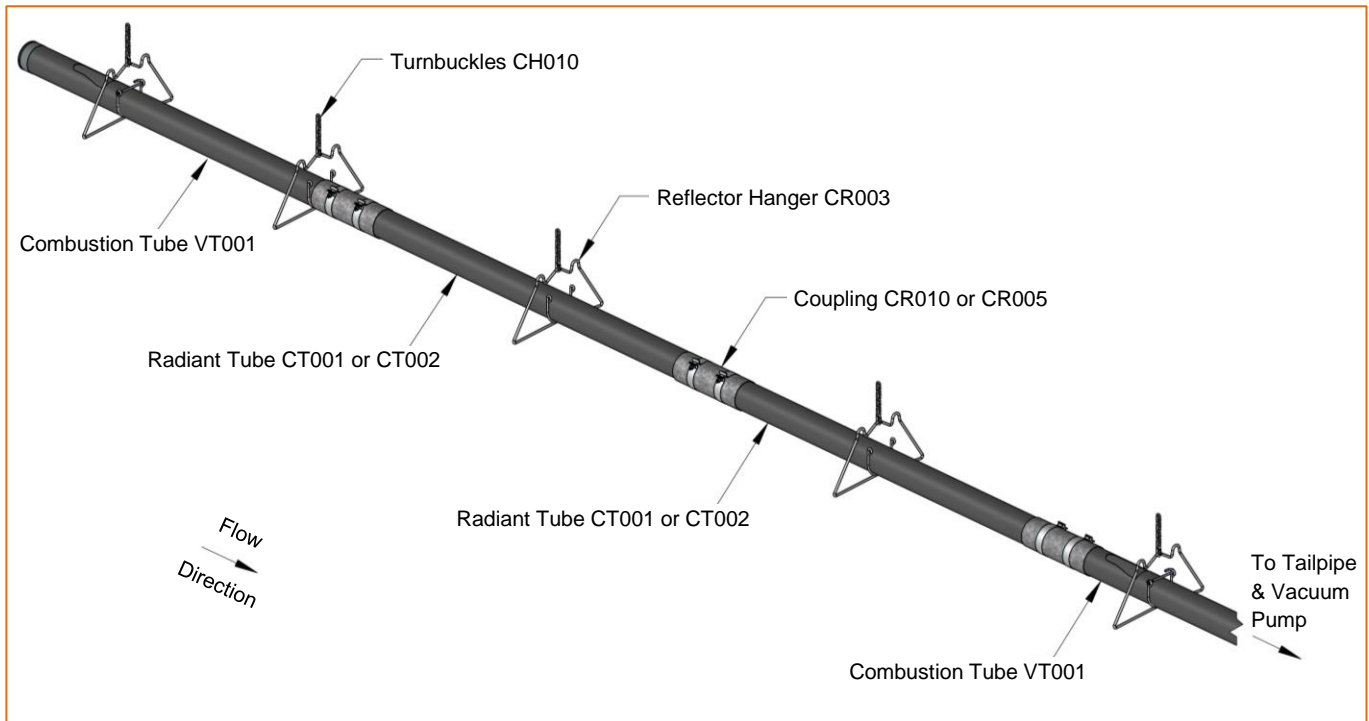

Figure 13: View of System after Installation of Radiant Line Tubes

Note: System is now ready for Tailpipe installation(s).

Note: System is now ready for Burner installation(s).

B - Tailpipe Tubes

1. Continue to install Hangers*, Tubes and Couplings as per Installation Part 1-A: Steps 1 to 5. Ensure that the mounting height allows a downward slope of $\frac{1}{4}$ " per 10 ft. (7 mm per 3000 mm) towards the Vacuum Pump location.
*On Tubes which will NOT have Reflectors, i.e. Tailpipe, the use of Hanger Straps instead of Reflector Hangers is approved.
2. BEFORE installing the Tee Section between the Branch Tailpipes and the Common Tailpipe determine where the Damper Couplings need to be installed.
3. Check which type of System is being installed, Symmetric (S) or Non-Symmetric (N) as per Figure 1 and Figure 2. Dampers are positioned to allow the Vacuum Setting at the Branch End Vent to be adjusted individually for each Branch. Symmetric/Identical Branches require the same Vacuum setting, so One Damper coupling is located before the Tailpipe splits into separate Branches. Non-Symmetric Branches require a separate Damper Coupling for each Branch. For Modulating Rate Systems ensure that Motorized Damper Couplings are used.

Damper Couplings are ONLY installed in the locations on the System where the respective letter reference "S", OR "N" is located in Figure 14, on all other connections use normal Couplings. Dampers and Couplings are installed using the same method. (See previous section.)

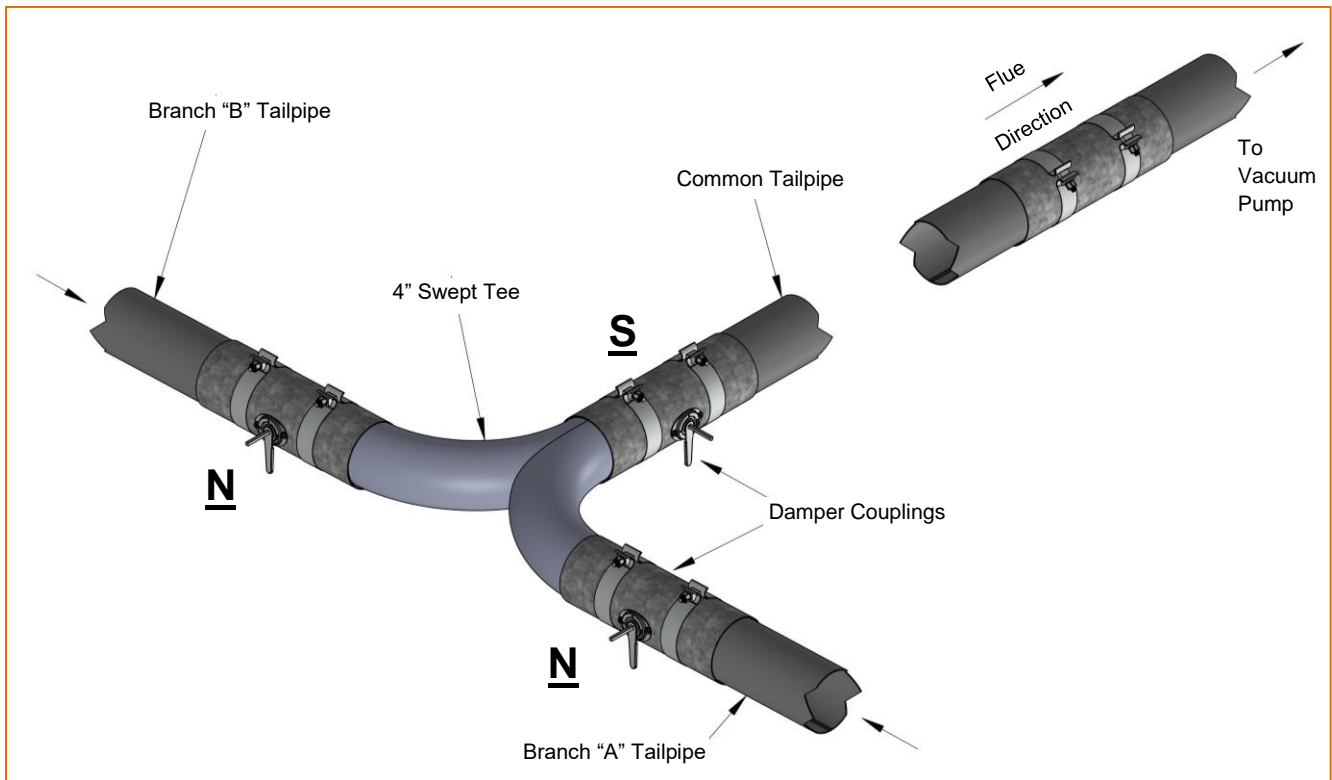

Figure 14: Typical Tailpipe Connections

- Continue to install the Common Tailpipe in the same manner as all other Tubing. Ensure that the mounting height allows a downward slope of $\frac{1}{4}$ " per 10 ft. (7 mm per 3000 mm) towards the Vacuum Pump location.

Note: System is now ready for Vacuum Pump and Ventilation connection(s).

C – Burners

Important

Each Burner in a Branch must be placed in its appropriate position, and have the appropriate Air Plate installed.

Burner Position No.1 is at the furthest end of the branch from the Vacuum Pump and the Burner number increases as the branch runs towards the Vacuum Pump.

(As shown in Figure 15 and referred to in your System Design Layout)

Verify that the Burners are correct for the fuel being burned.

- Confirm Burner Positions.

Each burner position in series along a branch requires the burner in that location to have a specific Air Plate installed. Burners will come with the Air Plate for a specific Position installed. The Position will be identified by the As-Built Burner Position Label (Burner No. #).

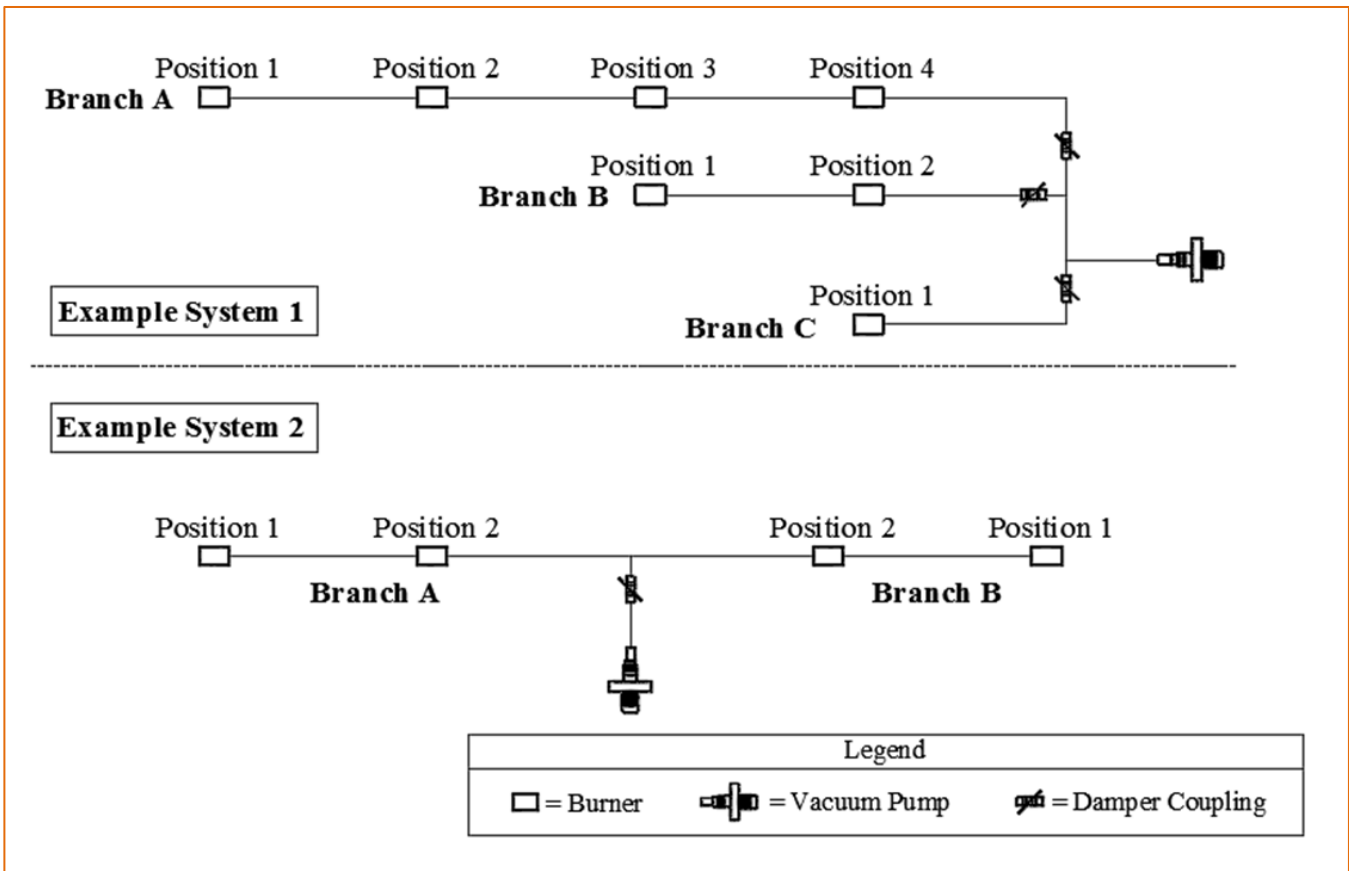

Figure 15: Burner Position Reference Diagram

2. Use the J-bolt (included with the Burner packaging) to clamp the Tube snugly at the first Reflector Hanger after a Burner mounting hole location. This prevents the Tube from rotating once the Burner is installed. (Refer to Figure 16 and Figure 18)
3. J-bolts must be installed before the Reflectors are inserted.

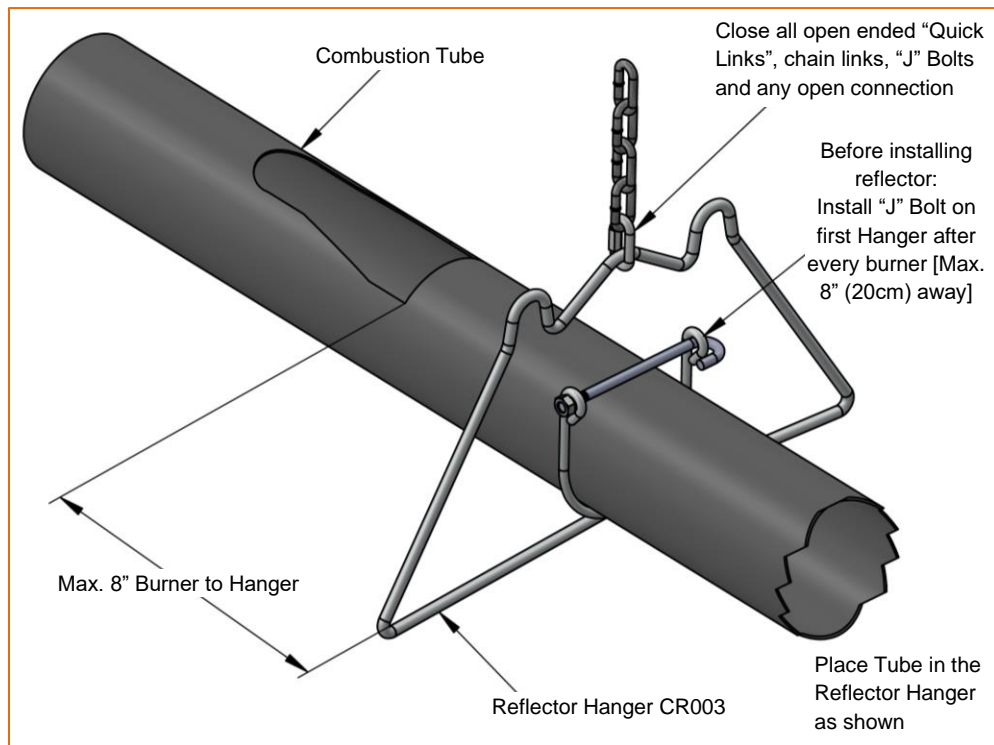
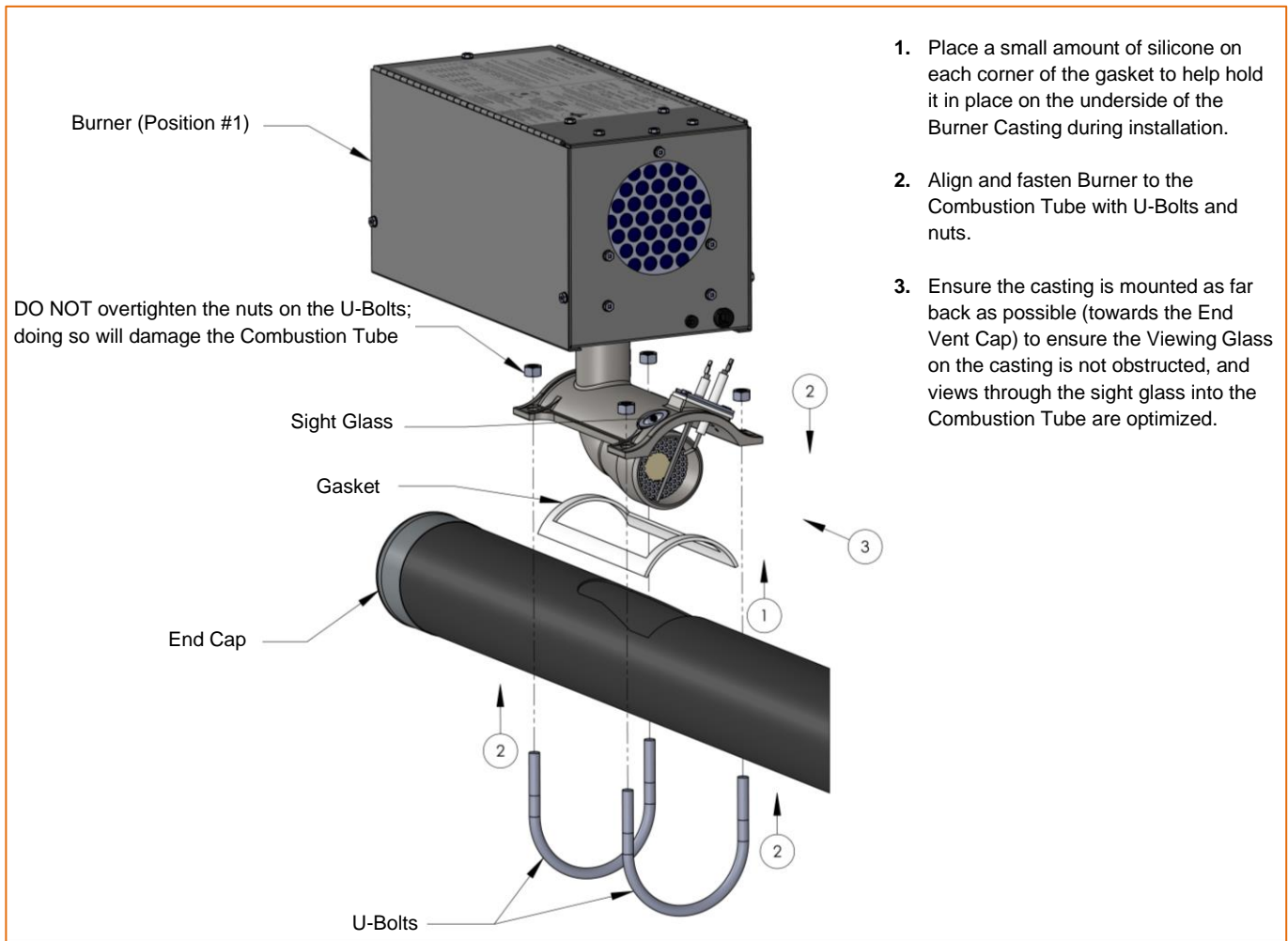

Figure 16: J-Bolt Installation Detail

4. Install each Burner. Ensure the gasket is properly in place, a small amount of silicon will hold the gasket. **Position the Burner completely to the back of the installation slot** as shown in Figure 17. Ensure that little or no Tube is in view through the Viewing Glass/Window.
5. Fasten the U-bolts but do **NOT** over tighten as it will damage the Combustion Tube.



1. Place a small amount of silicone on each corner of the gasket to help hold it in place on the underside of the Burner Casting during installation.
2. Align and fasten Burner to the Combustion Tube with U-Bolts and nuts.
3. Ensure the casting is mounted as far back as possible (towards the End Vent Cap) to ensure the Viewing Glass on the casting is not obstructed, and views through the sight glass into the Combustion Tube are optimized.

Figure 17: Burner Installation

Note: Burners are now ready for Fresh Air Supply connection(s) as necessary.

Note: Burners are now ready for Electrical System connection(s).

Note: Burners are now ready for Gas Supply System connection(s).

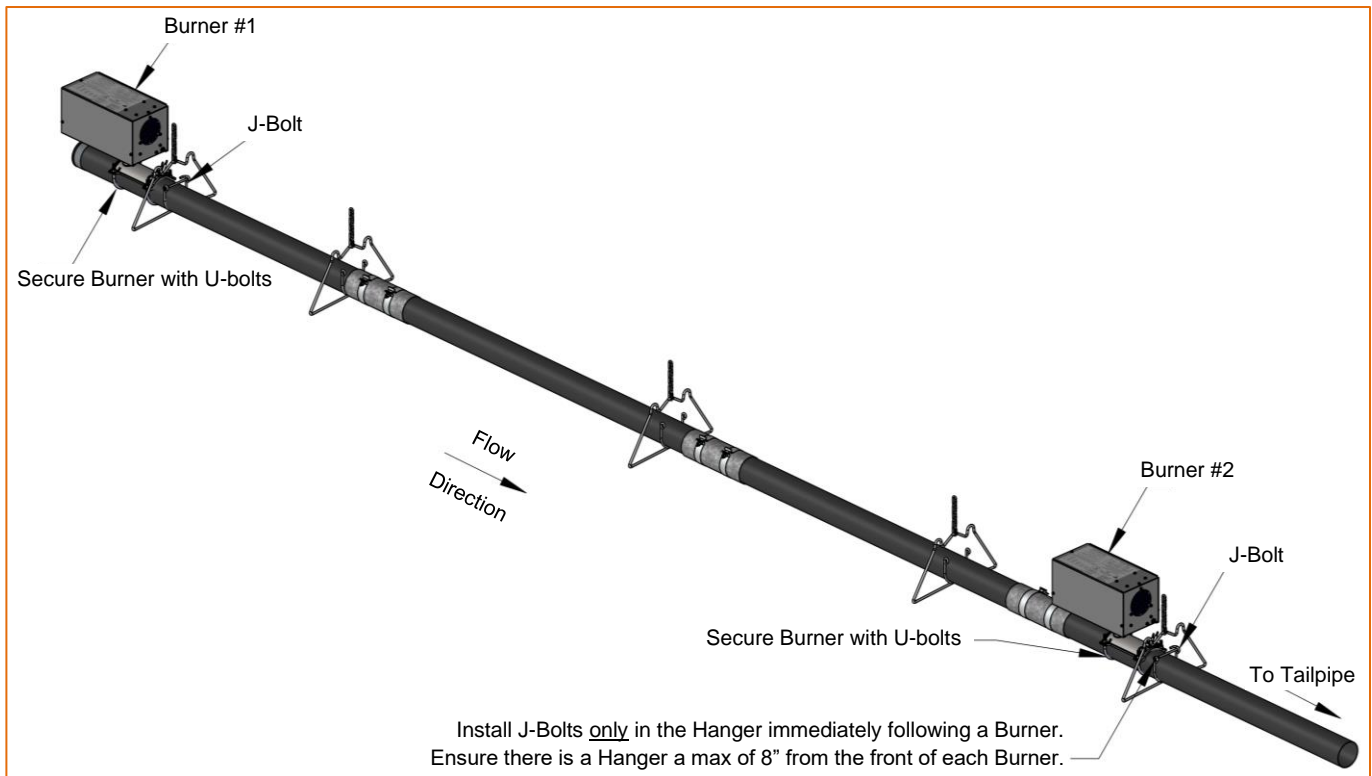

Figure 18: View of System after Installation of Burners

D - Reflectors

1. Install Reflectors after any Tube Couplings and J-bolts they cover have been installed. (For ease of installation it is suggested to install Burners before the Reflectors; however, it is possible to do the reverse.)
2. *If the System Plan includes Bottom Shields these MUST be put on before the Reflectors as there will be limited access afterwards. For details see Section E - Optional Shield Equipment.
3. Begin the first Reflector after a Burner with an End Cap about 3" (76 mm) downstream of the Burner as shown in Figure 19 and Figure 20. Install the End Cap using #8 x 3/8" screws. Leaving space in the Reflector run allows unimpeded installation and servicing of the Burner.
4. Install Reflector Brackets. Place one at each Reflector overlap position and one in the middle of each 10 ft. (3050 mm) Reflector length. Secure the Brackets loosely with #8 x 3/8" screws. Tighten only the screws for Brackets in the centre of alternating Reflectors and at every second overlap location. The remaining Reflector Bracket screws are left loose to accommodate system movement/expansion. Refer to Figure 20 below and to Figure 8 for a visual of which screws to tighten and which to leave loose.

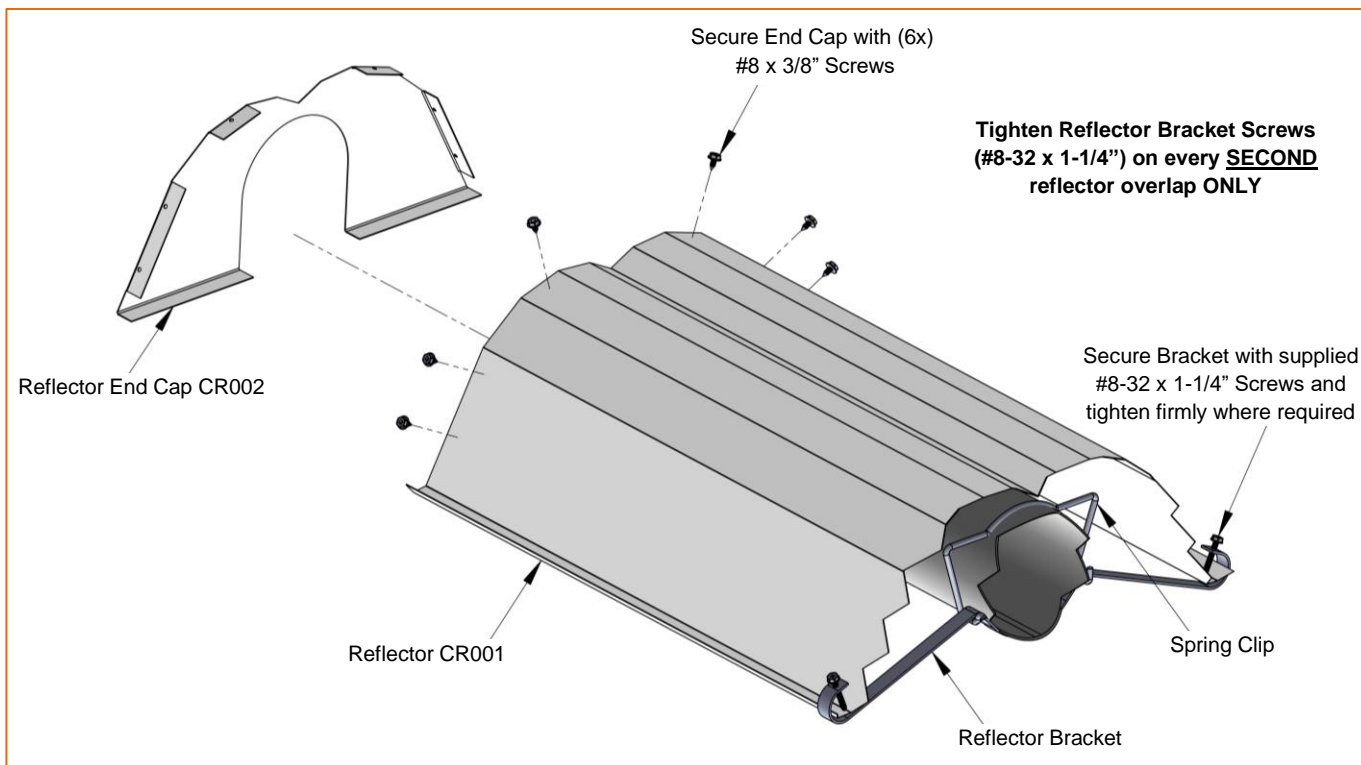

Figure 19: Reflector End Cap and Bracket Detail

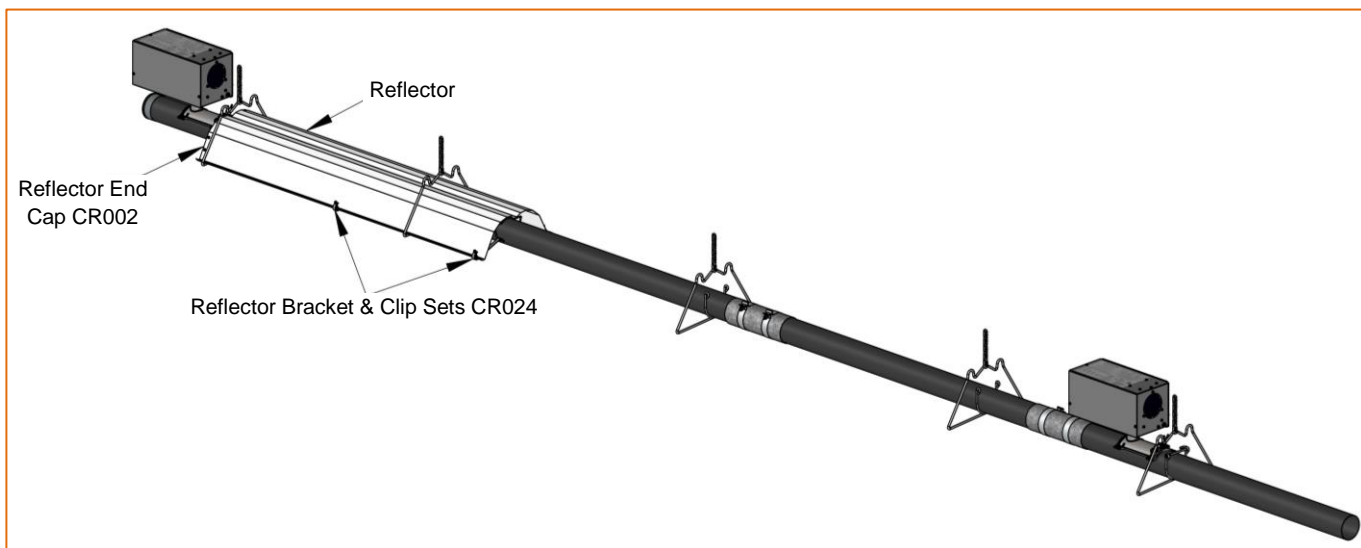

Figure 20: View of System after Installation of first Reflector

- Continue to slide the Reflectors into place within the Tube/Reflector Hanger up to the next Burner position. Overlap the Reflectors as shown in Figure 8 and Figure 22.

Note: Reflectors should overlap adjacent reflectors 4" to 6". Be sure not to tile reflector sections; that is, reflector sections must either be above both adjacent reflector sections or below both adjacent reflector sections.

- When approaching successive Burner locations, ensure the Reflector is as far under the Burner (close to the Burner mounting hole) as possible, as shown in Figure 21. *Install an End Cap using #8 x 3/8" screws on the open end of the Reflector which will be under the Burner at the end of the Reflector run.

*Burner Reflectors are for use instead of End Caps. If Burner Reflectors, for Continuous Reflector runs, are required by the System Plan please refer to Section E - Optional Shield Equipment for alternate Reflector installation details.

- Stop the Reflector run as per plan or when reaching an Elbow or Tee and install an End Cap at the end of the Reflector run using #8 x 3/8" screws.

*When using the optional Corner/Mitered Reflectors refer to Figure 25 in Section E - Optional Shield Equipment, for details on how to assemble Reflectors sections instead of installing End Caps.

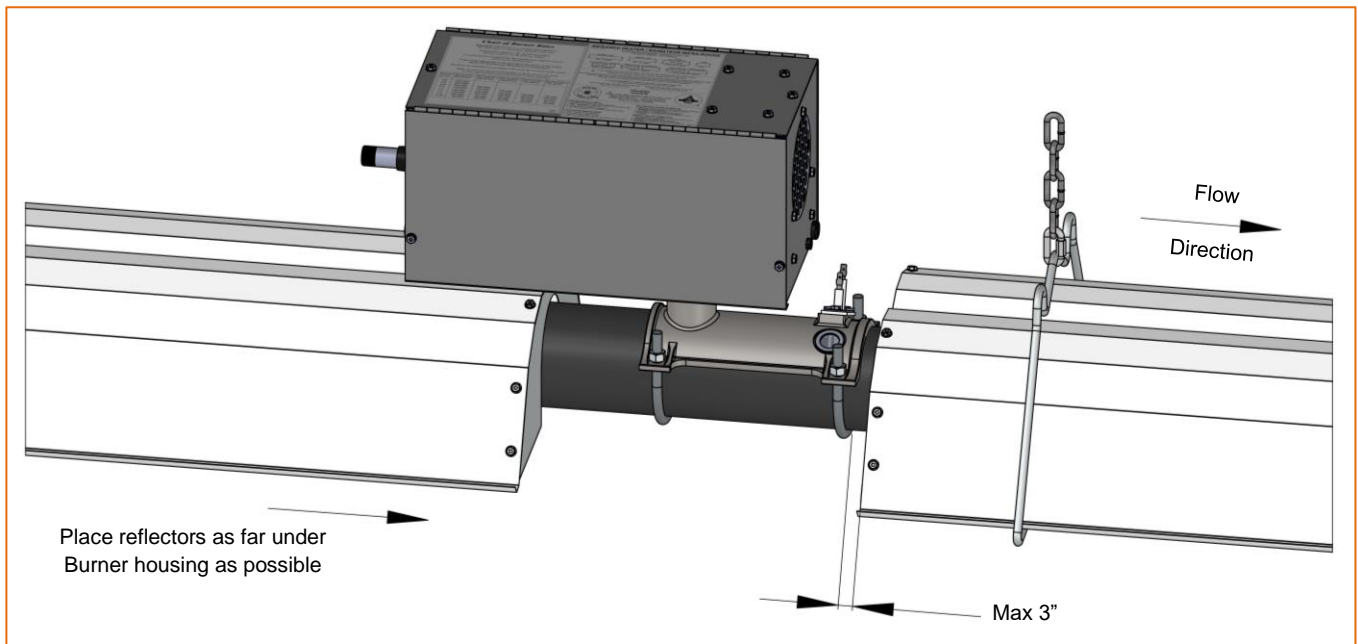

Figure 21: Standard Reflector and Burner Relative Positioning

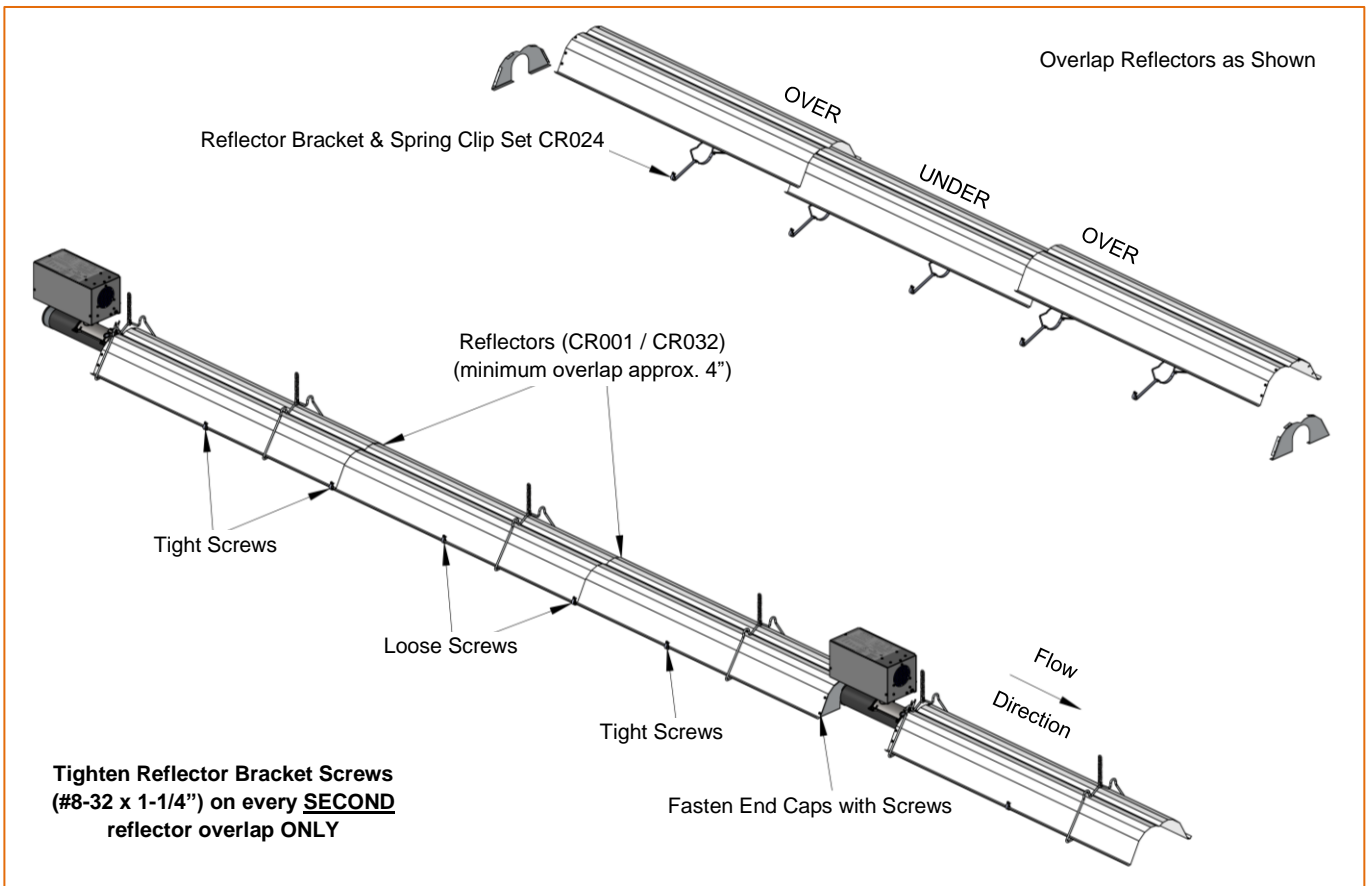

Figure 22: View of System after Installation all Reflectors

E - Optional Shield Equipment

Bottom Shields

Bottom Shields do not need to overlap. Each 5 ft. (1500 mm) section is held with two Support Brackets. Secure each of the Support Brackets around the Tube with supplied fastener and attach to bottom shield with #8 x 3/8" screws.

Refer to Figure 23 for reference.

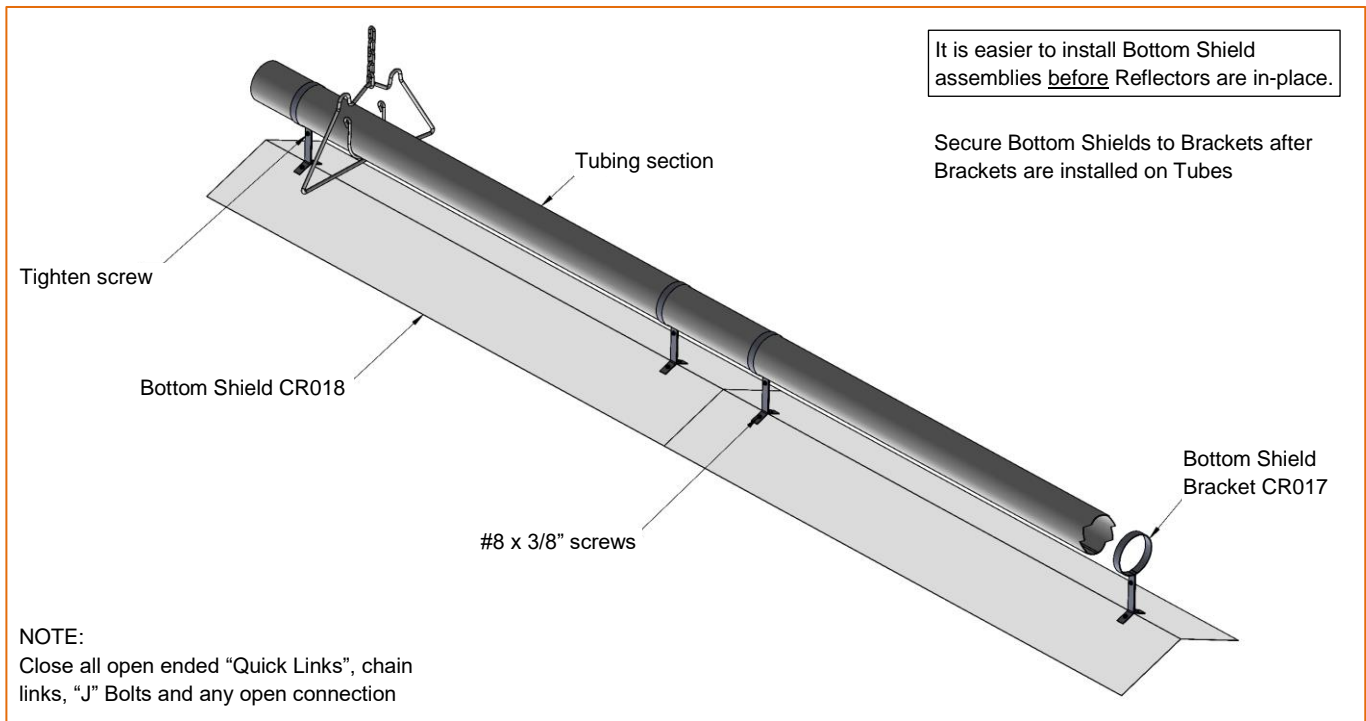

Figure 23: Bottom Shield Installation Detail

Burner Reflectors

Burner Reflectors are used to maintain a continuous Reflector surface along the length of the Heat Exchanger instead of ending and restarting Reflector runs with End Caps at each Burner location.

Burner Reflectors are installed after the Burner installation and before/during assembly of the main Reflector run. All pieces are connected using #8 x 3/8" Screws. The Side pieces and End Sections are installed first to create a Base to secure the Burner Reflector sections to. Overlap the Burner Reflectors with Standard Reflectors and secure the Reflectors together with Support Brackets. Refer to the sequence of images in Figure 24 for more detail.

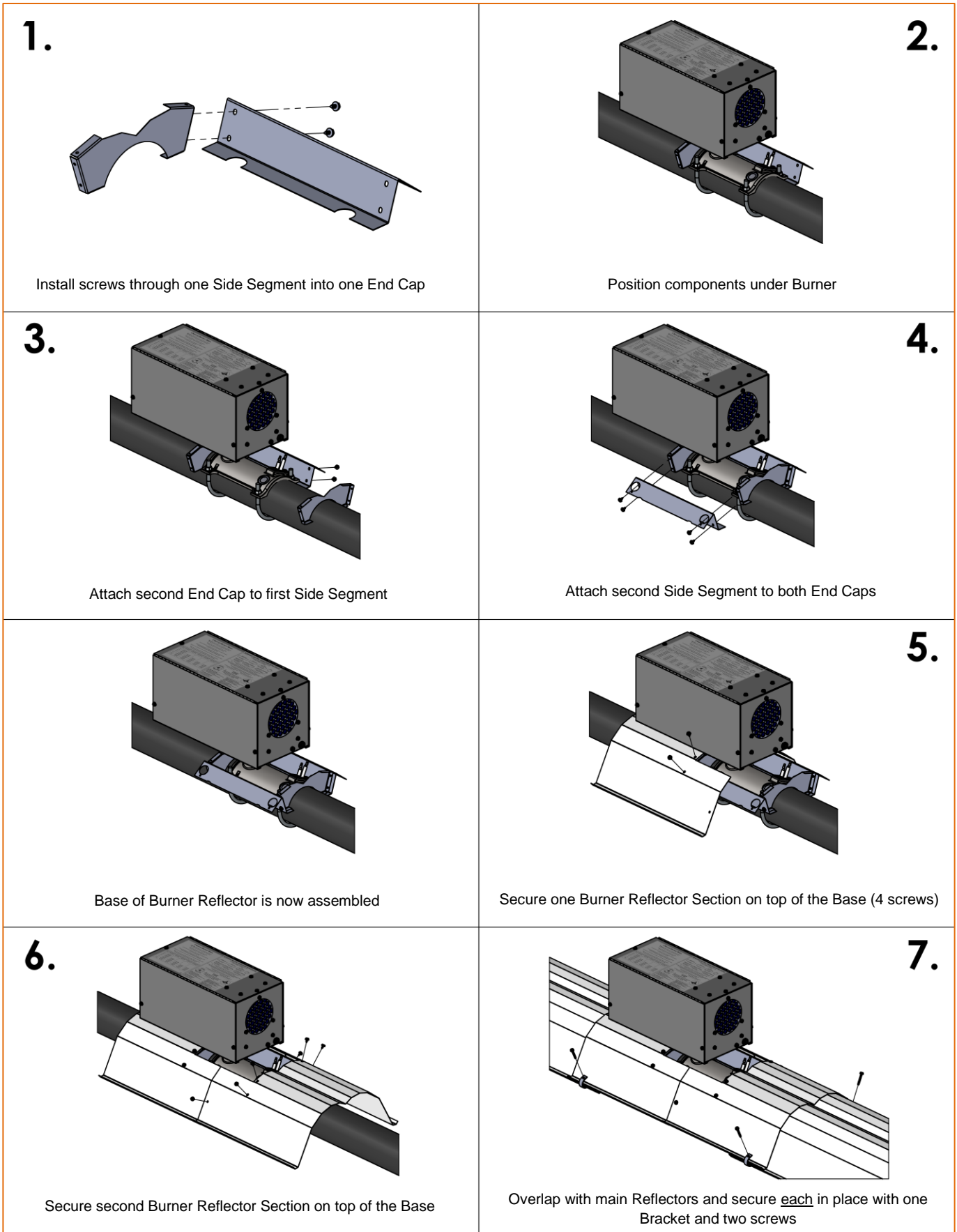

Figure 24: Burner Reflector Installation Sequence Details

Corner/Mitered Reflector

Corner/Mitered Reflector Kits are used above elbow locations instead of stopping and restarting a Reflector run to accommodate the elbow. Secure the Mitered Reflectors together using the Two (2) Corner Brackets as shown in Figure 25. Also insert #8 x 3/8" screws at each 'tab' location along the top of the Reflectors.

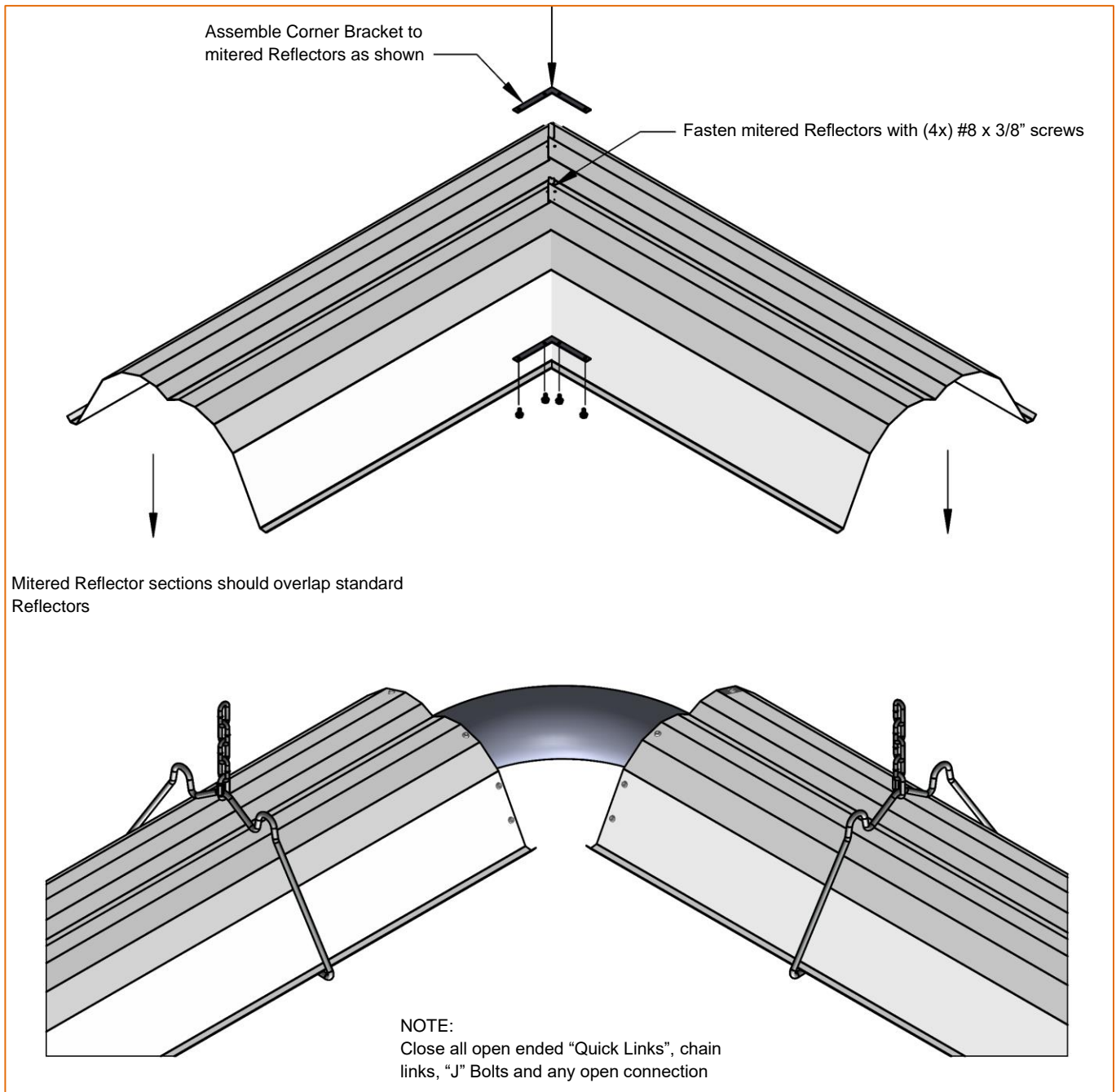

Figure 25: Optional - Corner (Mitered) Reflectors

Side Reflectors

Side Reflectors are 124" (3150 mm) long. Fasten one Side Reflector per main Reflector tightly with #8 x 3/8" screws spaced about 18" (500 mm) apart. Install three (3) Side Reflector Brackets per Side Reflector, spaced about 48" (1200 mm) apart, using #8 x 3/8" screws. DO NOT install brackets where Reflectors overlap. Refer to Figure 26 for details.

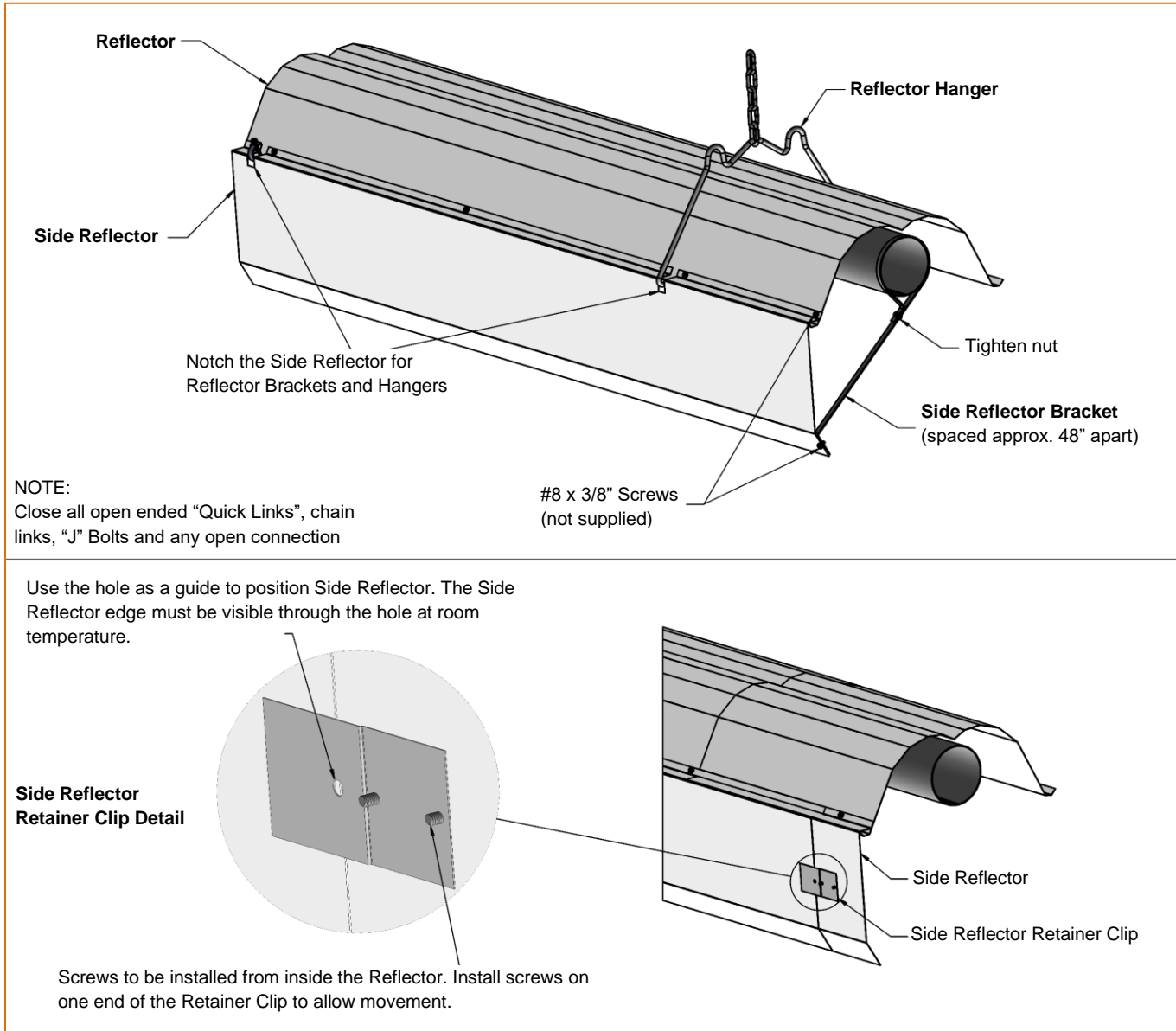

Figure 26: Side Reflector Installation Detail

F - Deco-Grille Option

CV systems are approved for the addition of a Decorative Grille [Deco-Grille] either directly to the Reflector or as part of a T-bar installation where the Heater System is above the ceiling structure. Refer to Figure 27 and Figure 28 below for their respective details.

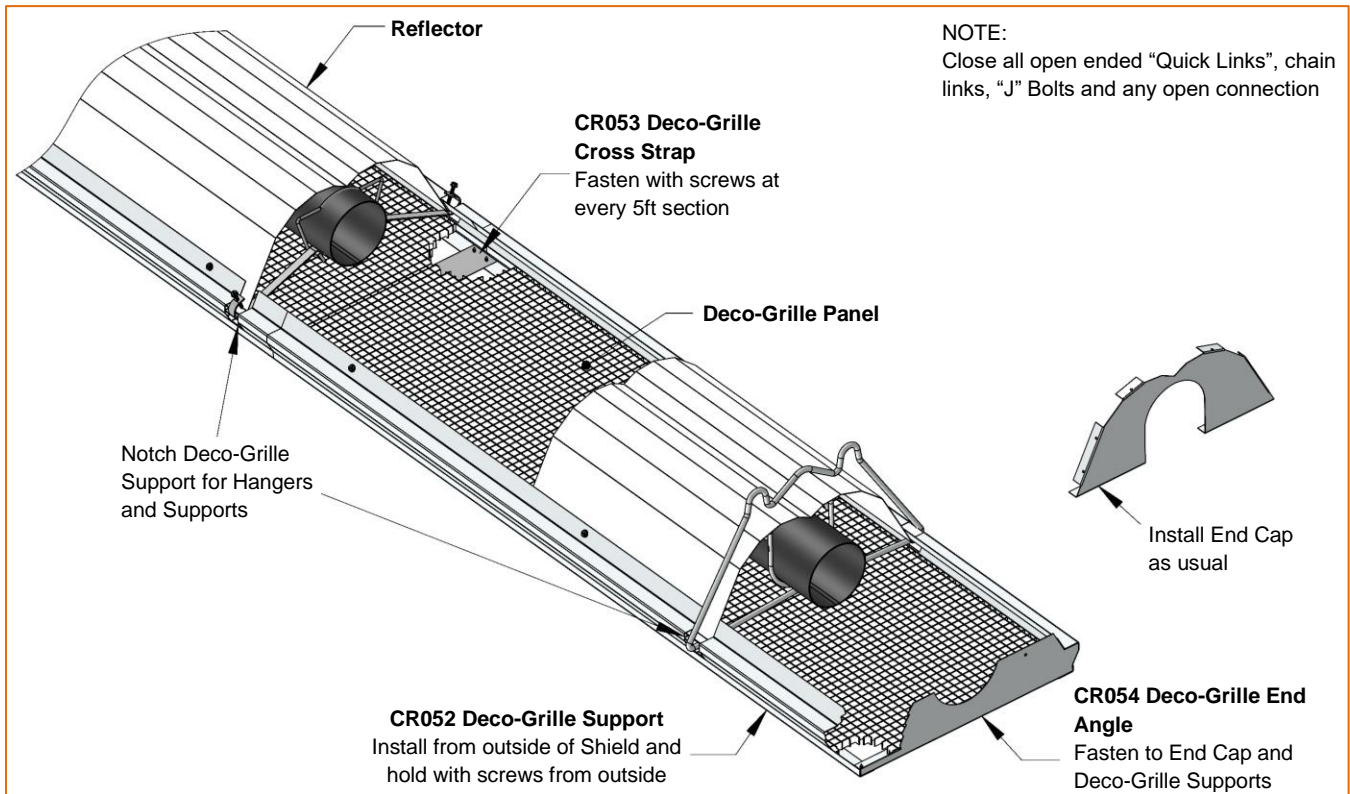

Figure 27: Deco-Grille – Mounted Directly to Heater

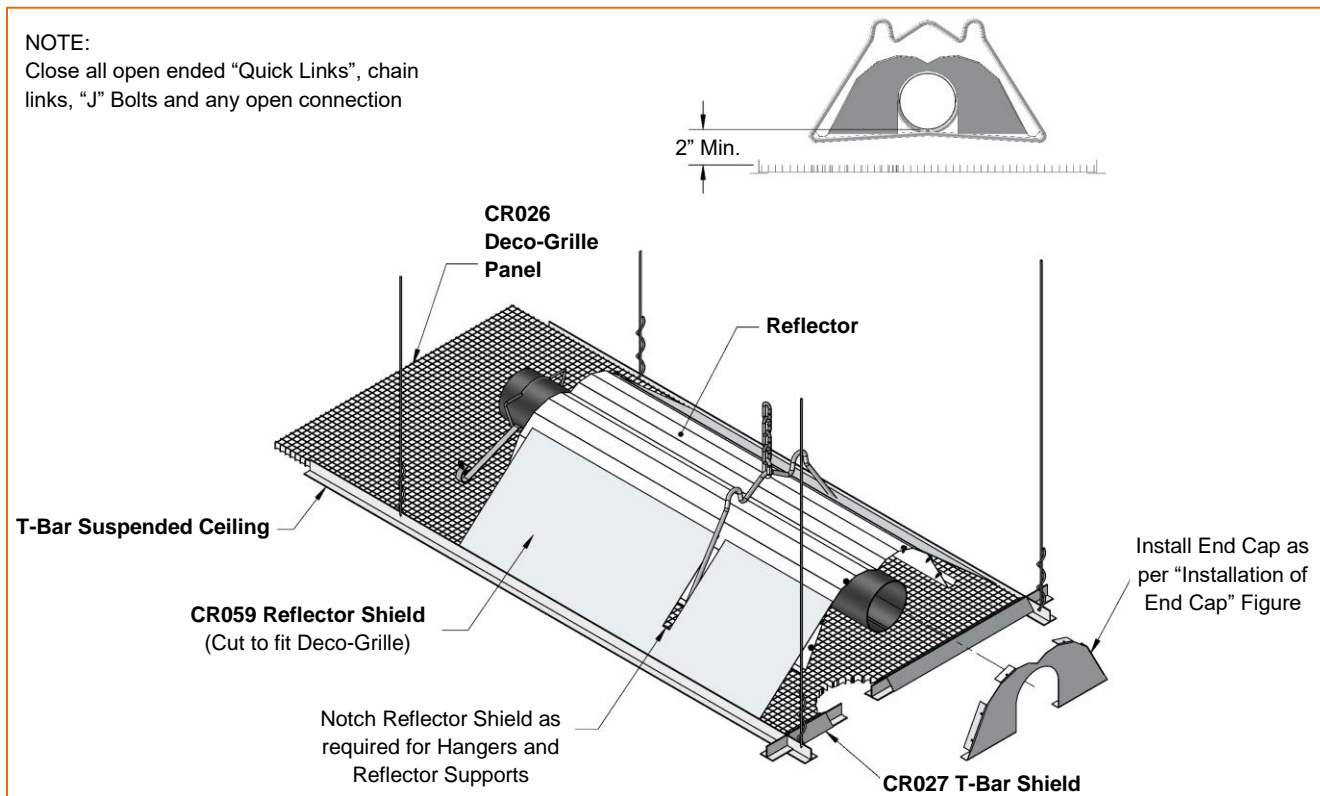

Figure 28: Deco-Grille – Mounted With T-Bar

2. Vacuum Pump and Venting

Vacuum Pump

General Requirements

The Vacuum Pump (with permanently mounted motor affixed) is generally located at the height of the system, bolted to a platform or support structure that is either suspended from the ceiling members or is bolted to a column or building sidewall. The Vacuum Pump scroll is orientated for the preferred horizontal discharge but can be rotated 90 degrees in the field for vertical discharge.

(Refer to Figure 29, Figure 30 and Figure 31 for visuals of Vacuum Pump mounting options.)

*If a lengthy heater run has a 90 degree elbow with a short run to the Vacuum Pump, consider placing the Pump somewhat off (past) the centerline of the connecting Tailpipe so that as the system grows the Flexible Boot Connection in fact improves performance.

Safety Warnings

Confirm that the Vacuum Pump's impeller rotates in the same direction indicated by the arrow on the pump scroll. To reverse rotation, see instructions on the motor.

WARNING - DO NOT OPERATE THE VACUUM PUMP WHEN NOT INSTALLED
- Unguarded openings can entangle clothing and severe injury can result
- Unrestricted air flow into Vacuum Pump can cause the motor to overload

To ensure maximum safety, a vacuum proving switch is mounted near the inlet of the vacuum pump and electrically interlocked to the burner power circuit. No fuel gas can flow, or ignition begin, before the vacuum proving switch has established the presence of a blower induced vacuum.

See the "Electrical Connections" section for details on wiring the switch.

Vacuum Pump Mounting

1. Install Vacuum Pump as per designed system mounting location and position.
2. Ensure that mounting supports are sufficient to withstand the weight and vibration of the Vacuum Pump and Ventilation System. Welded link chain with a working load limit of at least 200 lbs. (91 kg) is recommended for mounting vacuum pumps only.
3. Install using the Vacuum Pump Mounting Kit if purchased. (Chain and threaded rods for ceiling mounting are NOT included in package.)
4. Ensure elevation of Inlet will allow for the alignment of the Tubing with a downward slope of ¼" per 10 ft. (7 mm per 3000 mm) towards the Vacuum Pump.
5. Ensure that the isolators are placed between the Pump housing and the mounting supports to reduce vibration transfer to the structure.

See Figure 29, Figure 30 or Figure 31 respectively for mounting type details (right-hand discharge models shown).

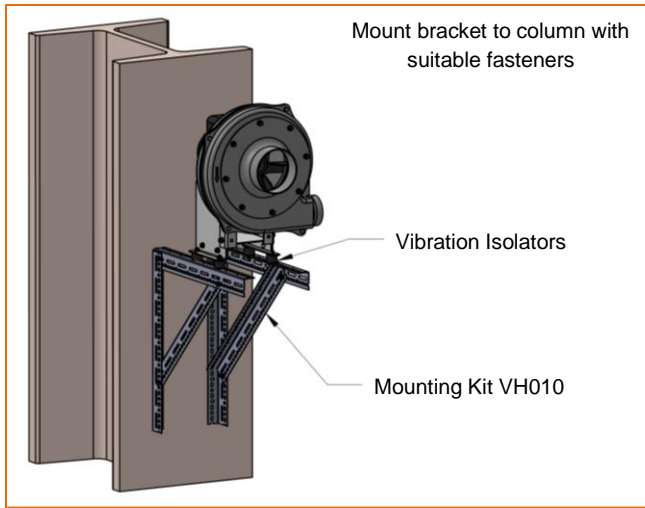

Figure 29: Column Mounting – Recommended Pump Suspension

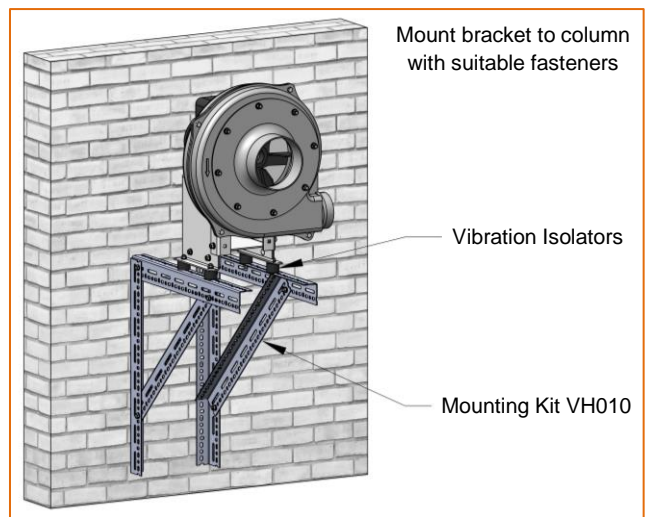

Figure 30: Side Wall Mounting - Recommended Pump Suspension

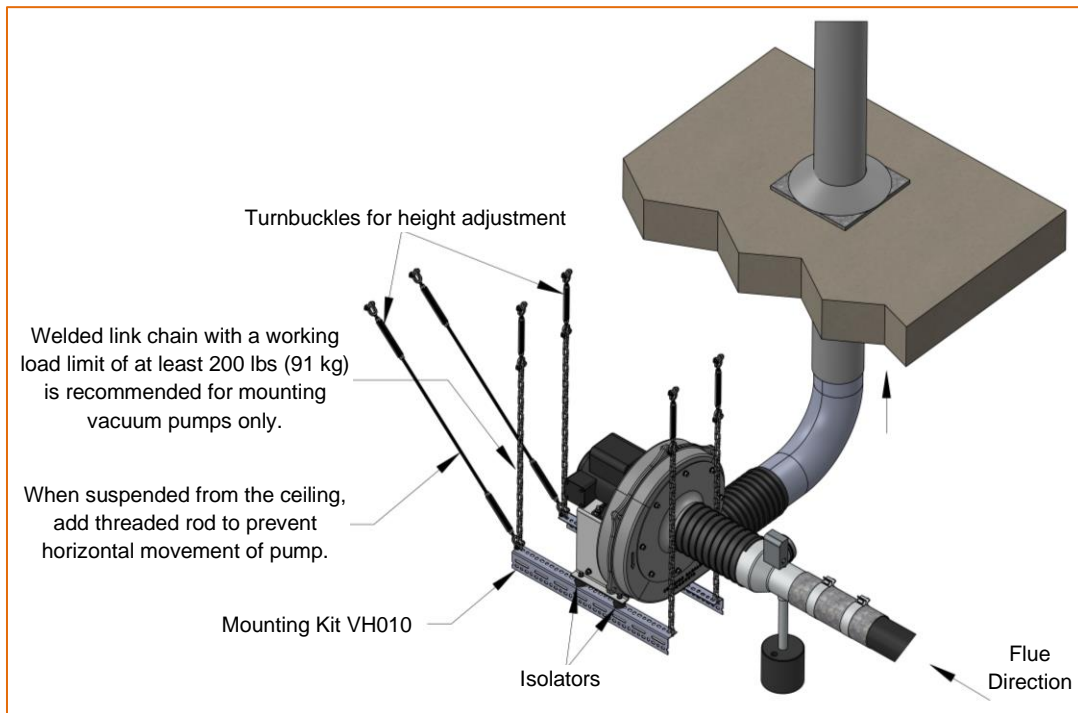

Figure 31: Ceiling Mount - Recommended Pump Suspension

Venting

General Requirements

The CV system should be installed in accordance with the relevant provisions of National Standards and Codes of Practice in the destination country.

Systems can be operated according to B52 appliance type.

In buildings having an air change rate of less than 0.5 per hour, additional natural or mechanical ventilation is required.

- Natural ventilation: Ventilation openings with a free area of at least 2 cm² per kilowatt of rated heat input shall be provided.
- Mechanical ventilation: Sufficient ventilation air shall be provided to ensure that the building air change rate is at least 0.5 per hour.

Note: When flued horizontally, the flue pipe must be arranged to provide a continuous rise from the appliance of 6mm per 1m length.

Note: The flue gas temperature downstream of the heater is at maximum 200 °C.

The CV System are approved for both Sidewall (Horizontal) and Roof (Vertical) Venting.
(Refer to Figure 32 and Figure 33)

General Installation Notes

- Never connect venting to a chimney flue serving a separate solid fuel burning appliance.
- Rigid, spiral wrap, corrosion resistant ducting is recommended to facilitate leak-proofing the system. Venting runs over 25 ft. (7600 mm) in length may need to be insulated.
- Always install venting with a down-slope of at least ¼" per 10 ft. (7 mm per 3000 mm) towards the Vacuum Pump location.
- Ensure that ducting is well suspended to avoid low spots where condensate can gather.

System Requirements

Horizontal Venting:

Size: 4inch (100 mm) or 6inch (150 mm) dia. as per Vacuum Pump Outlet
Sealant: RTV Silicone
Fasteners: Minimum of Two (2) sheet metal screws #8 x 3/4" per joint.

Table E: Size Conditions for Exhaust Venting

Vent Length [ft (m)]		Vacuum Pump A		Vacuum Pump B	
Maximum	Minimum	Vent Dia.	# Elbows	Vent Dia.	# Elbows
10ft (3050 mm)	2ft (600 mm)	4 Inch (100mm)	Up to 2	6 Inch (150mm)	Up to 3
50ft (15000 mm)	2ft (600 mm)	5 Inch (125mm)	Up to 2		

For specific Part Numbers of Wall Vent connection pieces see Figure 32 or the listing in the PARTS section of this manual.

Vertical Venting:

- For Vertical Venting refer to National Standards and Codes of Practice in the destination country.

Ventilation Connections

Install Ventilation system pipes, etc. as per design/conformance with required Codes and connect with Vacuum Pump Outlet. Ensure that there is a minimum of 2" (50 mm) between the Vacuum Pump outlet and the first rigid section of the Ventilation piping to avoid mechanical contact between the two. Use the Silicone Connector Boot to connect the Vent Pipe to the Vacuum Pump Outlet.

(Refer to Figure 32 or Figure 33 respectively for mounting type details.)

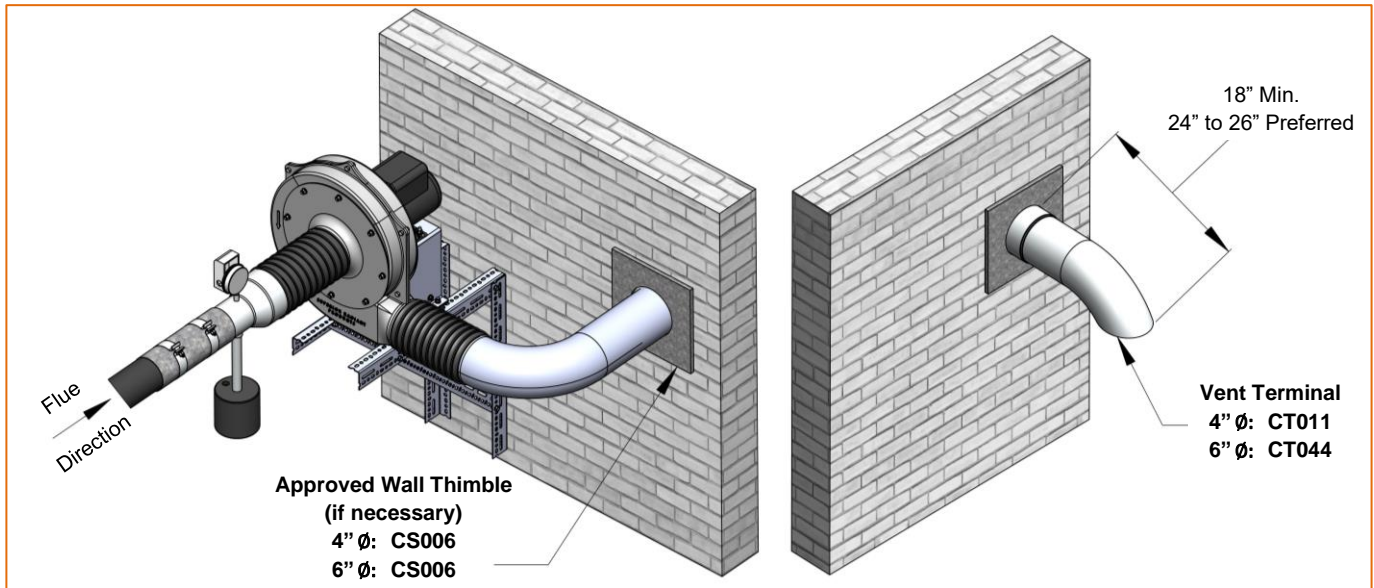

Figure 32: Side Wall Mounting - Recommended Venting (Horizontal)

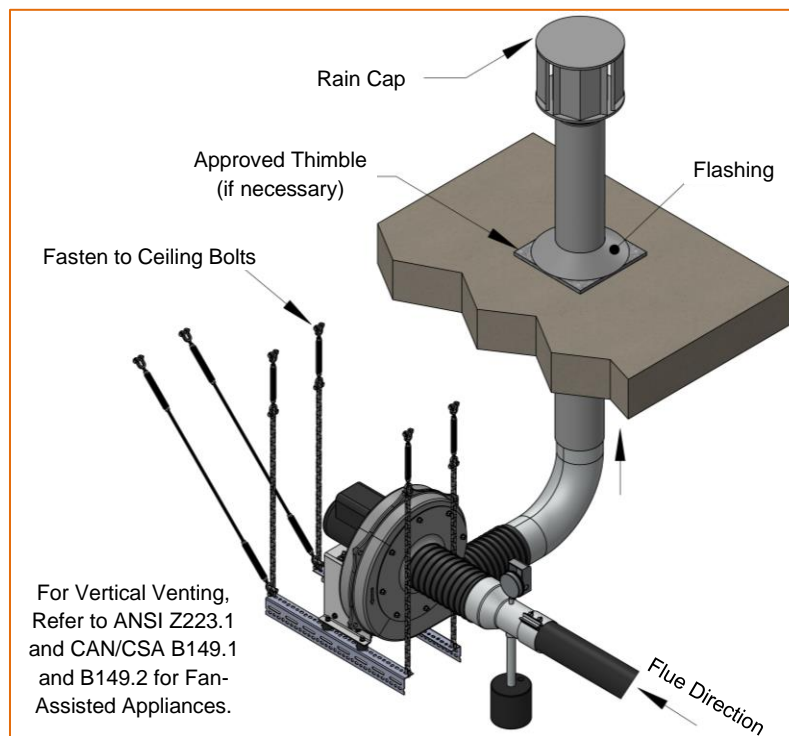

Figure 33: Ceiling Mounting - Recommended Venting (Vertical)

Additional Pump Connections and Equipment

1. Connect the Reducer to the end of the Common Tailpipe using a 4" (100 mm) Butt Joint Clamp. Ensure a minimum of 2" (50 mm) clearance between the Reducer and the Pump Inlet.
2. Install the Flexible Boot Connector between the Reducer and Pump Inlet, to reduce vibration and noise transmission, using a gear clamp at either end, as shown in Figure 34.

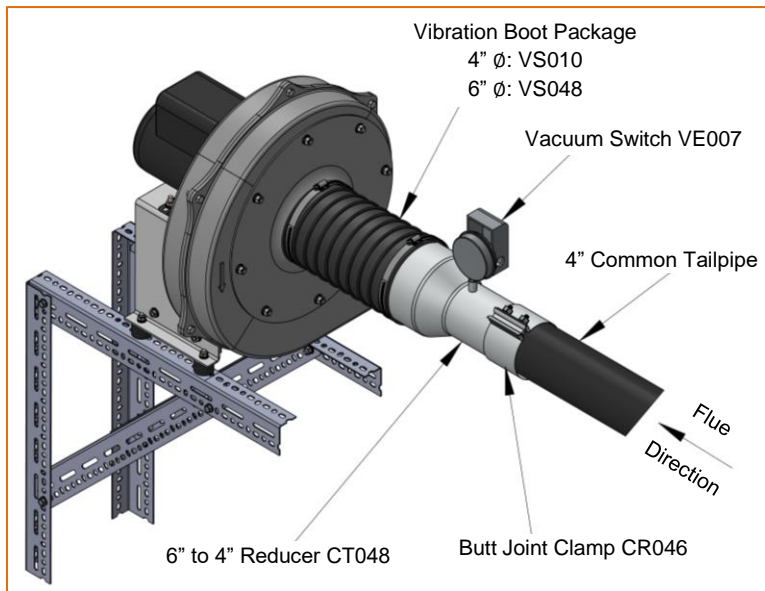

Figure 34: Tailpipe to Vacuum Pump Connections

3. Seal all joints and seams using high temperature Silicone Sealant (RTV Silicone).
4. Where condensing designs are specified, a Condensate Drain may be installed as shown in Figure 35. Ensure connection to Drain Pipe is flexible to allow for system movement/expansion during operation, and that an appropriate Neutralization Device is installed as required.

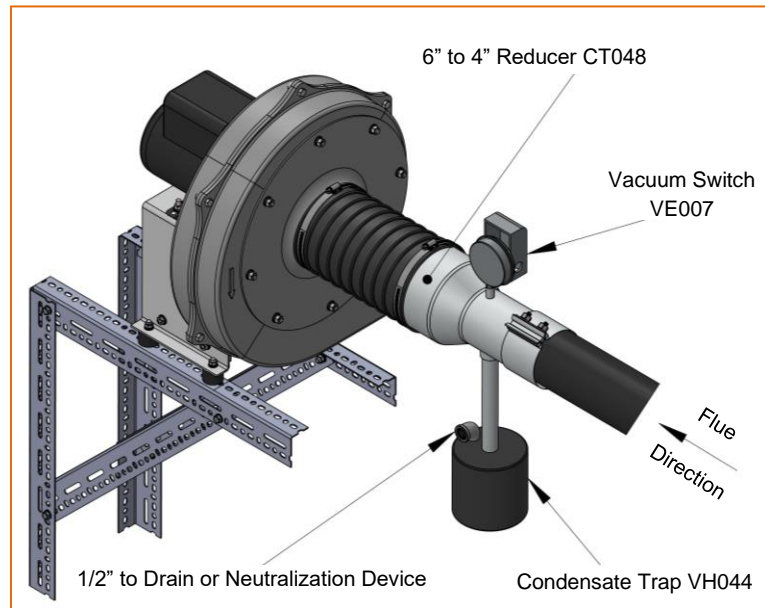

Figure 35: Condensate Drain Detail – Optional

WARNING: DO NOT APPLY ANY FORCE OR PHYSICAL PRESSURE ON THE AIR SWITCH. USE WRENCH ON THE METAL FITTING TO INSTALL THE AIR SWITCH. PRESSURE PORT WILL BREAK IF INSTALLED BY HAND.

3. Optional Combustion Air Supply

An air supply at atmospheric pressure of 25 m³/h per 10 kW to each Burner and the end of each Radiant Branch (at the End Vent Cap) is usually sufficient.

Under certain circumstances of very dirty or wet environments, or extremely negative building pressure, a Combustion Air Supply System that is connected to the fresh air outside the building may be recommended. The Combustion Air Supply System must be designed with accepted HVAC design methods to ensure adequate supply of air to each Burner and Radiant Branch. This Combustion Air can be supplied using a Blower. Supply at the Burner must be at atmospheric pressure therefore it may be necessary for the Installer to insert Damper Couplings to allow adjustment of pressure just before the connection to each Burner and at the end of each Branch. **The Blower must be electrically interlocked with the Vacuum Pump, details can be found in “Electrical Connections”.**

Combustion Air Supply Duct Connections

1. Install Blower if required.
2. Install Combustion Air Supply ductwork and Damper Couplings as required.
3. Each Burner can be fitted with a 4” (100 mm) dia. fitting to accept 4” (100 mm) dia. Type C-Duct or 4” (100mm) PVC pipe. Provision for thermal expansion of the System must be made when considering Combustion Air Supply Ducting. Ensure that the System movement/expansion does not restrict the supply of fresh air to the Burners or the Radiant Branches. (Refer to Figure 36 for clearance requirements)

As required, connect the Supply Ductwork in the same manner as for the Burner. (Refer to Figure 36 for details), **DO NOT** remove the End Vent Cap from the Radiant Branch to make this connection.

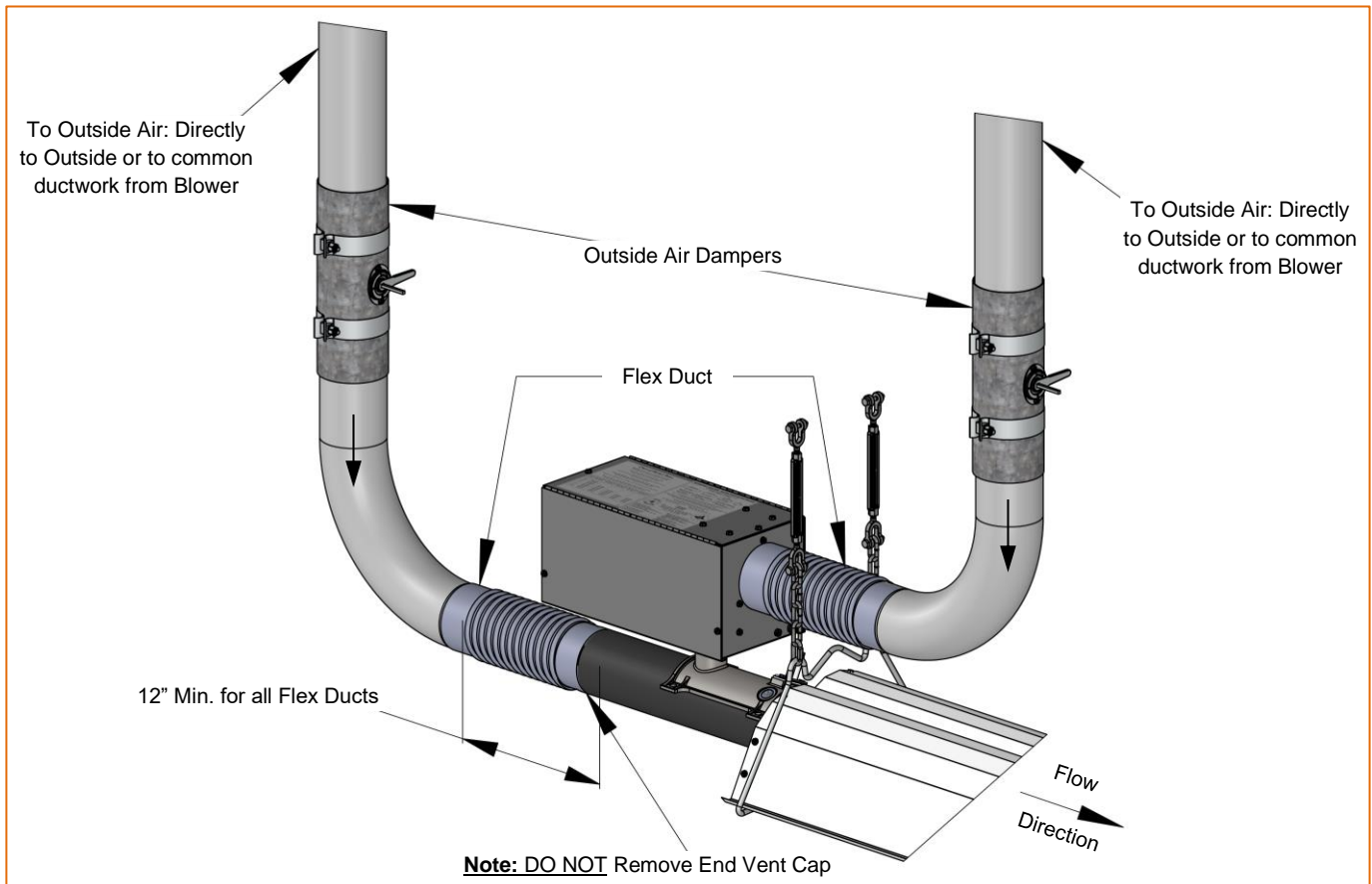

Figure 36: Outside Combustion Air Detail

4. Gas Supply System

General Requirements

Supply Lines

The Gas Supply Meter and the Supply Service must be sufficiently large to supply gas to the total building gas load including the heating equipment. Additionally, the gas distribution piping must be designed according to local and national ordinances. Generally, systems designed with a maximum 1/2" W.C. (1.25 mbar) total pressure drop (low pressure) meet this requirement.

Gas supply pipe sizing must be in accordance with the National standards and Codes of Practice in the destination country. Minimum size to be 12.7 mm (1/2") bore.

A 1/8" NPT plugged tap must be installed in the Gas Line connection immediately upstream of the Burner farthest from the Gas Supply Meter to allow checking of system gas pressure.

A Gas Shut-off Valve must be installed parallel to EACH Burner Gas Inlet connection.

Before connecting Burners to the Gas Supply System, verify that high pressure testing of the Gas System has been completed. Burners must be isolated from any pressure testing in excess of 1/2 psi (3.5 kPa).

Failure to comply may expose the Burner components to damage due to high pressure, requiring replacement of key components.

Flexible Gas Connector Lines

Flexible gas hoses used for the installation of radiant tube heaters shall be of stainless-steel construction. The minimum diameter of the hose shall not be less than the diameter of the inlet connection. The minimum length of the flexible hose shall not be less than 0.5 metres. The maximum length of the flexible hose including the fittings shall not be greater than 2 metres.

Flexible gas hoses shall meet the requirements of EN 14800:2007. National standards and Codes of Practice in the destination country must be adhered to.

Below 44 kW	12.7mm (1/2") Flexible gas connectors	CG012
-------------	---------------------------------------	-------

Failure to install the Gas Connection in the approved manner will result in a hazardous and potentially deadly situation due to the movement of the heat exchanger and burner in the normal course of operation.

Installation or repair of this heater should only be done by personnel qualified for the installation of powered gas appliances.

(Certified by the local or national regulating body)

Flexible Gas Connector Line

A Flexible Gas Connector of approved type and size must be installed as shown in Figure 37, in one plane, and without sharp bends, kinks or twists. A smooth loop of approximately 12" (300 mm) in diameter is best. Refer to Figure 37 for examples of correct and incorrect positioning

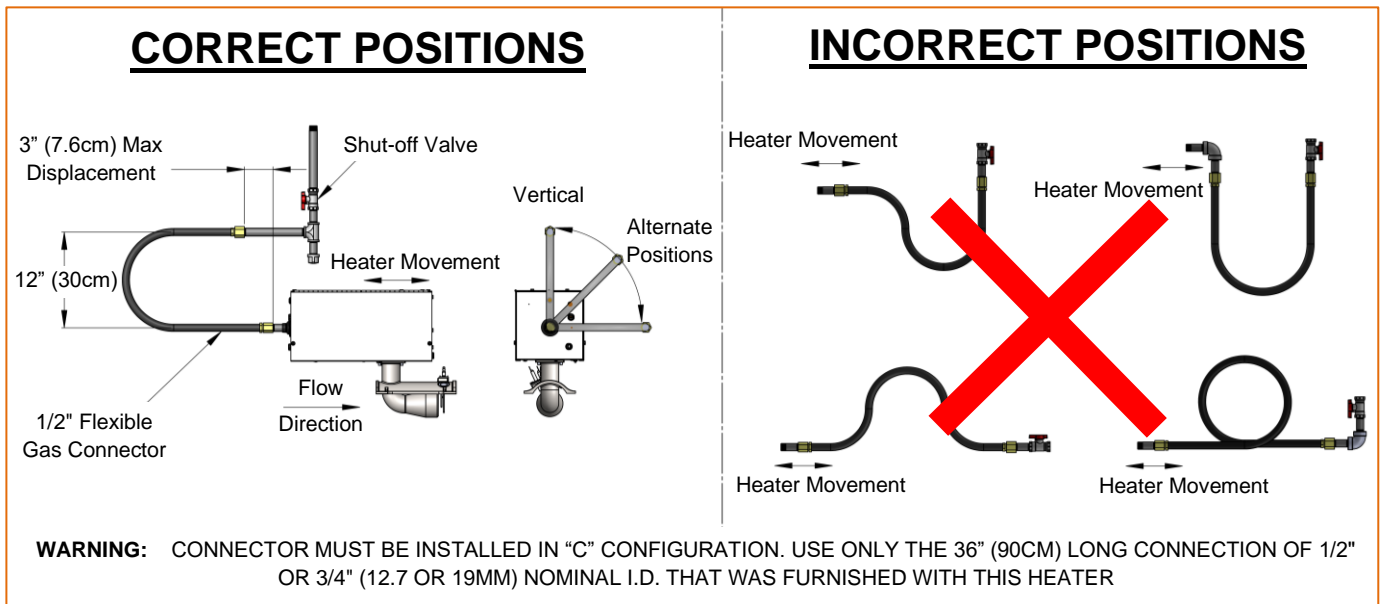

Figure 37: Connector & Installation Position Instructions

5. Electrical Connections

General Requirements

The electrical wiring to this heater must be installed in accordance with National Standards and Codes of Practice in the destination country.

Ensure that all Electricity to the Supply locations involved has been 'disconnected' and 'locked out' as per local and national safety requirements before proceeding with any part of the Electrical installation.

General Wiring

All field wiring and connections must be in accordance with the Standards and Codes of Practice in the destination country and must comply with all local requirements.

All systems must be connected and electrically grounded in accordance with the Standards and Codes of Practice in the destination country and must comply with all local requirements.

Thermostats

Thermostats must be located/mounted within the operating heat envelope of the Radiant Line Branch being controlled. Thermostats must be protected from direct 'line of sight' with the Radiant Tubing and Reflectors.

Control Methods and Devices

1. **Single Thermostat:** Entire system operates as one Heating Zone, ON or OFF using one Relay to control the Vacuum Pump, Vacuum Switch and Burner Power.
2. **Multiple Thermostats:** System Branches operate as multiple individual Heating Zones which can be separately controlled ON or OFF. Burners are controlled ON/OFF by the Thermostat.

Figure 39 shows wiring diagram of controlling up to four heating zones (branches) and one system (one vacuum pump) with up to four single stages thermostats.

Figure 40 shows wiring diagram of controlling one system (one vacuum pump) with a modulating thermostat.

Contact manufacturer for other control options.

Burners

Maximum current draw is 0.1 A per burner. Burners internally operate on 230 VAC and 50 Hz. A connector is supplied to connect on 230 VAC, 50 Hz system. Burner wiring between the connector, gas valve, control module and timer has been completed by the manufacturer as shown in the Figure 38. Wiring label is located on the burner service door.

Any repair/replacement of the manufacturer's wiring must have a minimum temperature rating of at least 105°C and supply circuit wiring shall have a minimum size of 18 AWG.

Fresh Air Blower Interlock

If a Blower is installed to achieve the 23 m³/h per 10kW of Fresh (Combustion) Air Supply requirement then an 'interlock' connection must be made between the Blower and Vacuum Switch (and therefore the Vacuum Pump).

1. Mount the Vacuum Switch and make the connections to the Blower as required. (See Figure 40 for details)
2. Ensure that field wiring maintains the required clearances when being routed near equipment.

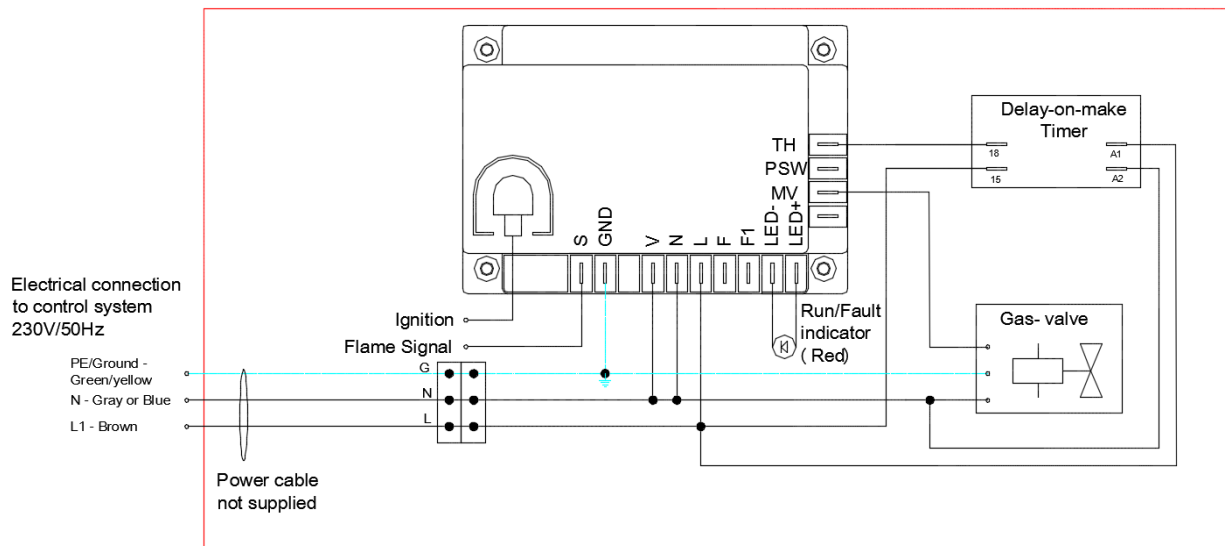

Figure 38: Burner Wiring Diagram

System Wiring Connections

1. Ensure that field wiring maintains the required clearances when being routed near equipment.
2. Mount ALL Electrical components as required by Code(s) and Heating Zone system Plan/Layout.

Reminder: Ensure that all Electricity to the supply locations involved has been 'disconnected' and 'locked out' as per local and national safety requirements before proceeding with any part of the electrical installation.

3. Mount the Thermostat(s) as per plan. Wire the Thermostats into the system Control Panel. Sample Control Panel diagrams are shown in the following pages.
4. Wire the Electrical Power wiring to the Control Panel according to the device OEM Manual, as required for the Heating Zone system Plan/Layout.
5. Mount/position the Vacuum Switch onto the Radiant System as shown in Figure 34. Connect the Vacuum Switch to the Vacuum Pump and the Control Panel.
6. Connect the Electrical Power Supply to the Control Panel and all other equipment as shown in the sample Control Panel diagrams in the following pages.
7. Test all connections/wires as necessary.

DO NOT energize Control Panel with Electrical Power until it is time to complete the COMMISSIONING of the System.

8. Confirm that the Vacuum Pump's impeller rotates in the same direction indicated by the arrow on the pump scroll. To reverse rotation, see instructions on the motor.

WARNING - DO NOT OPERATE THE VACUUM PUMP WHEN NOT INSTALLED

- Unguarded openings can entangle clothing and severe injury can result
- Unrestricted air flow into Vacuum Pump can cause the motor to overload

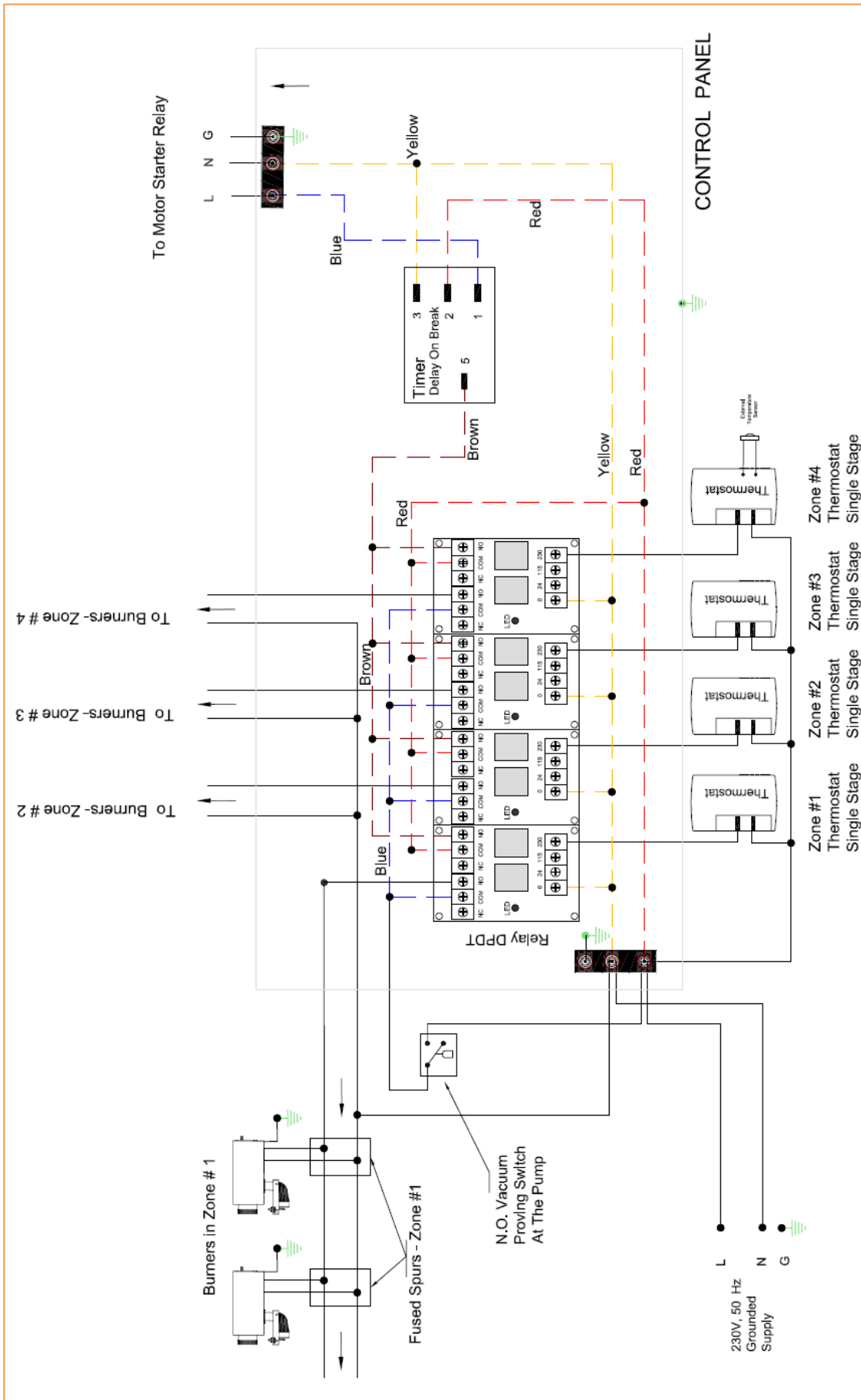

Figure 39: Control Panel Wiring Diagram (Optional)
 Four Heating Zones, Single-Stage Fire Mode, Post-Purge Timer

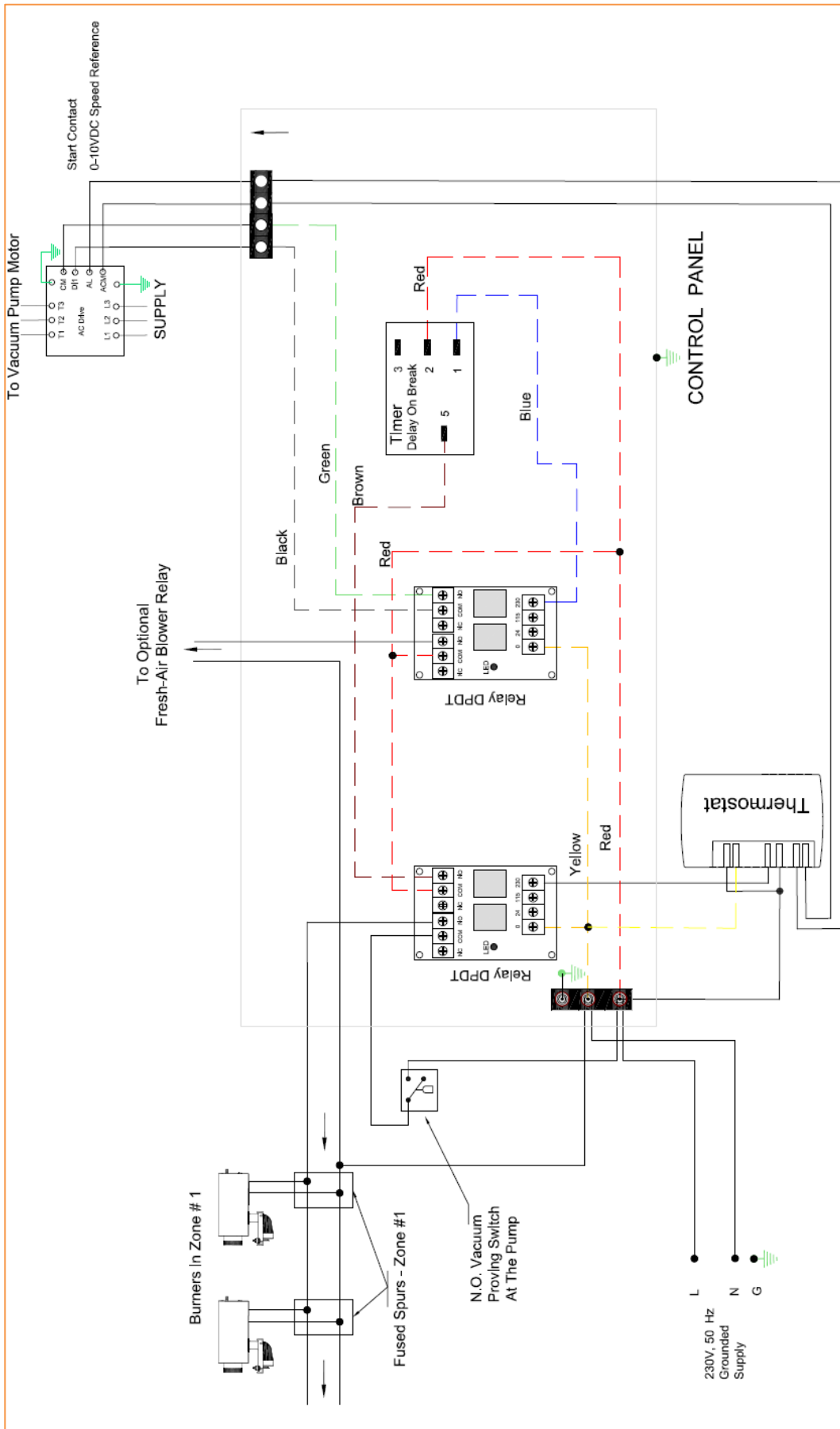

Figure 40: Control Panel Wiring Diagram (Optional)
 One Heating Zones, Modulating Fire Mode
 Fresh-Air Blower Relay Interlock, VFD for Pump and Post-Purge Timer

COMMISSIONING

1 - Installation Checklist

Before proceeding with the start-up of the system, review the list of items below to ensure proper operation.

- Close all Quick links and turnbuckles to avoid unlocking chain with inadvertent contact
- Verify that the Burners are correct for the fuel being burned. The rating plate listing this information is located on the Burner housing, check this against your site plans.
- Burners are position dependent. For proper operation, ensure that the Burner labeled as 'No. 1' on the housing is located at the end of each Radiant Branch. Subsequent Burners in each Branch must be positioned sequentially.
- Burners should be mounted with the Burner casting as far back in the Tube opening as possible. Ensure that little or no Tube is in view through the viewing window.
- Ensure that the End Vent Cap is oriented with the ¼" (6 mm) test hole at the 12 o'clock position and that it has been secured to the end of each Branch with a #8 x 3/8" screw.
- If you have both hot rolled Tube (black and shiny) and heat-treated aluminized steel Tube (matte gray), ensure that the heat-treated aluminized Tube is used in the Tailpipe section of the system.
- Ensure that Tubes are fully inserted in the Couplings and tightened with band clamp hardware at the 10 or 2 o'clock position. Tighten band clamps alternately to prevent buckling of the Coupling sleeve.
- Ensure that each Branch has a Damper Coupling at the end of the Radiant length, as well as one at the Vacuum Pump. If the system is symmetrical, one Damper along the Common Tailpipe may be used. Single Rate Systems will use standard Manual Dampers while Modulating Rate Systems will use Motorized Dampers.
- Ensure that Reflectors are properly overlapped and that every second overlap joint is screwed together, as shown in Figure 8. The remaining joints are left loose. This will allow the Reflectors to 'telescope' with the thermal expansion of the System.
- Visually confirm that the Vacuum Pump's impeller rotates in the same direction indicated by the arrow on the pump scroll. To reverse the rotation, see instructions on the motor.
- Ensure that EACH Flexible Gas Connector is of sufficient size for the desired Burner rate and is installed in a smooth arc with no kinks.
- Purge Gas Lines according to installation codes
- Verify the Wiring and that the Electrical Power Supply is connected but remains turned OFF.

Refer to Figure 8 for Radiant Line System –Component Relationships

2 - Initial System Power Test

With the individual gas valves to each burner 'Shut off' perform the following:

1. Ensure Gas Supply is turned OFF. (Open main gas valve and ensure that no gas is flowing through the gas meter [dial test].)
2. Verify that lock-up gas pressure is not above the maximum supply pressure, listed on page 11.
3. Set all thermostats below room temperature and turn ON main power – no part of the System should be energized.
4. Check each Radiant Branch in each Zone in sequence by turning up the appropriate Thermostat. In each case the Vacuum Pump should turn on and, after the pre-purge time, the Burners in that Zone should attempt to light.
5. Troubleshoot as necessary to get the System operational. (See the Trouble-Shooting section of this manual for more detailed information and helpful notes.)

3 – Cold Balancing the System Vacuum

NOTE: The CV burner is a variable rate appliance. Vacuum Pump setting must be accurately adjusted to ensure Burners are operating at the specified design input.

1. Turn ON the Electrical Supply but NOT the Gas Supply (remains turned OFF). You may also disconnect the air switch to allow for system cold balancing. This will let you start the vacuum pump without energizing any burners.
2. Allow the system to run without Burners operating.
3. With a manometer check the vacuum at the End Vent Cap of the longest Branch. (Refer to Figure 41 for manometer positioning details.)
4. Adjust the Damper that is installed in the Tailpipe of the same Branch to obtain the vacuum readings according to Table F below. (In Systems that are "Symmetrical" there will be only one Damper along the Common Tailpipe.) A cold vacuum will always be higher than a hot vacuum, so compensation should be factored in for cold balancing as follows – add 1 mbar for each burner in a zone. If your desired end result hot setting is 7 mbar and you have two burners in a row in that zone, set your cold vacuum to $7 + 1 + 1 = 9$ mbar. Mark the Damper positions for future reference.
5. Proceed similarly until each individual branch in the system is balanced/adjusted.
6. Shut down the System.

Refer to Table F: Vacuum System Settings for Relative Burner Rates

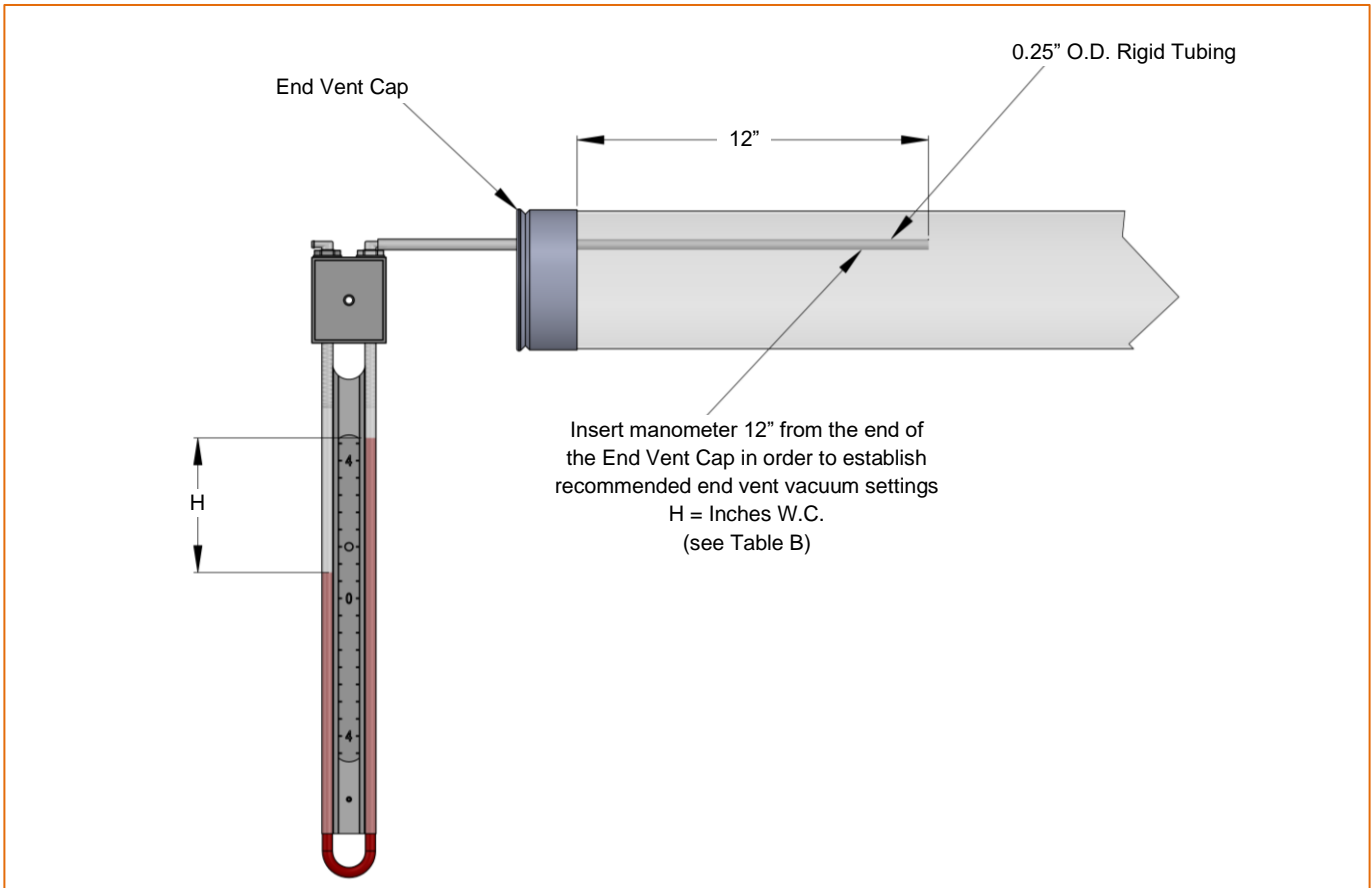

Figure 41: Manometer Placement Diagram

Table F: Vacuum System Settings for Relative Burner Rates

	Burner Position 1	Burner Position 2	Burner Position 3	Burner Position 4	End Vent Vacuum
	kW	kW	kW	kW	mbar
CV 35	35 35	35 35	35		8.0
CV 32	32 32	32 32	32		7.0
CV 29	29 29	29 29	29 29	29	7.0
CV 23	23 23	23 23	23 23	23	7.0
CV 18	18 18	18 18	18 18	18	7.0
CV 12	12 12	12 12	12 12	12	7.0

4 – Burner Time Delay Setting

- Once you have acquired the proper cold start End Vent Vacuum, go to the burner closest to the vacuum pump on that branch.

NOTE: Burner Position No.1 is at the furthest end of the branch from the Vacuum Pump and the Burner number increases as the branch runs towards the Vacuum Pump.

NOTE: In most applications we would like to see the burner closest to the pump to start up first. If you have a system with only one burner in a branch, all you need to do is set the End Vent Vacuum and plug in the heater. No burner adjustment should be needed.

NOTE: Each burner has a Delay-on-make Timer as seen in Figure 42 below.

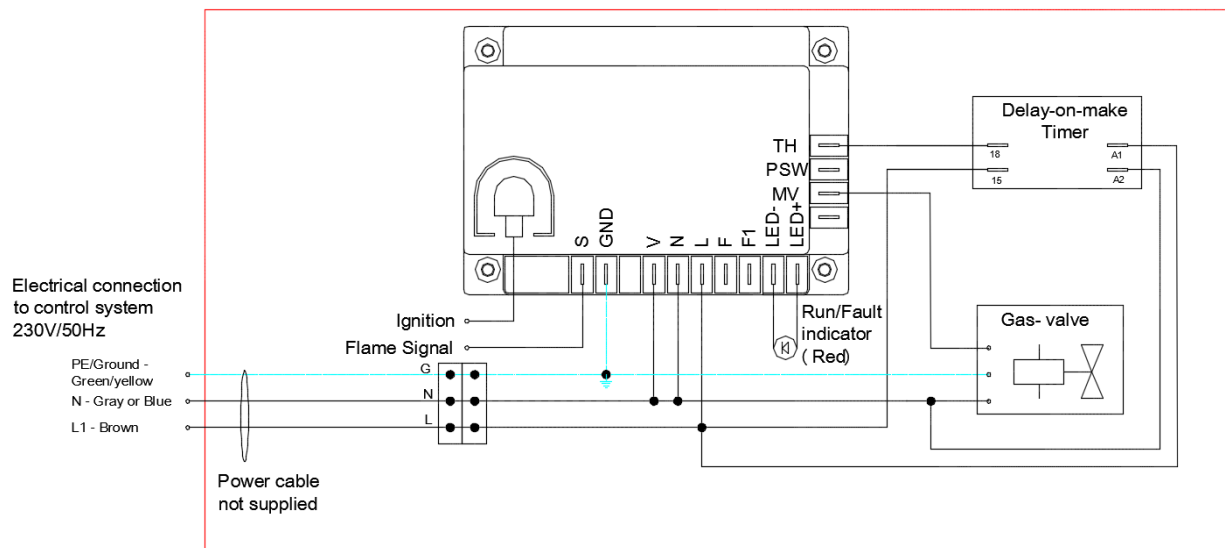
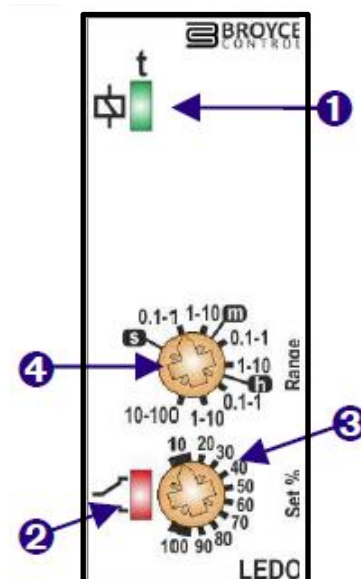

Figure 42: Delay-on-make Timer

- Set the Delay-on-make Timer settings of all burners to ensure at least 60 seconds delay between the consecutive burners. For a 3-burner branch, set Burner #3 for 30 seconds, Burner #2 for 60 seconds, and Burner #1 for 120 seconds.

Setting Details

- Power supply status / Timing (Green) LED
- Relay output status (Red) LED
- “Set %” adjustment
- Time delay “Range” selector



5 – Burner Adjustment

1. Now we are ready to start up the burner. Before plugging in the burner, take the cap off the Maxitrol Zero Regulator. Refer to Figure 43 below to locate Zero Regulator.

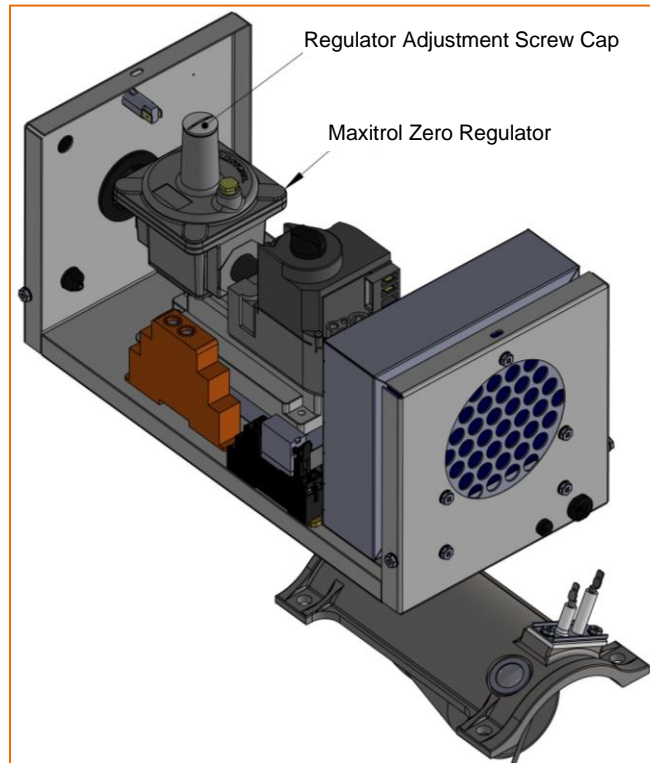

Figure 43: Maxitrol Zero Regulator

NOTE: The Maxitrol Zero Regulator takes the incoming gas pressure and reduces it down to zero. The gas valve is set to a specific setting so that it acts mostly just like a gate valve, open and closed. The gas pressure is knocked down to zero, the gas valve opens and the vacuum sucks in the amount of fuel it needs. You never want to adjust the gas valve. We make all fuel adjustments with the Zero Regulator **ONLY**.

NOTE: These burners are at their optimum performance when they are **burning their leanest** (least amount of fuel possible but still lit). When they are running rich, they can make high pitch harmonic noises.

2. The zero regulators come factory set as shown in Figure 44. Make sure the one you are working on has not been tampered or set incorrectly.
3. Make sure the gas supply line has been purged then switch/connect in the burner to the main 230V supply.

NOTE: Once energised, the burner will try to light. In some conditions the burner will light, some may not light, and some may light intermittently.

4. If your burner will not stay lit or will intermittently light you may need to adjust the Zero Regulator. Refer to Figure 45 and the following sequence.

NOTE: The gas valve is screwed into a square mixing chamber as seen in Figure 45. On the opposite side of the mixing chamber our air plate is screwed on.

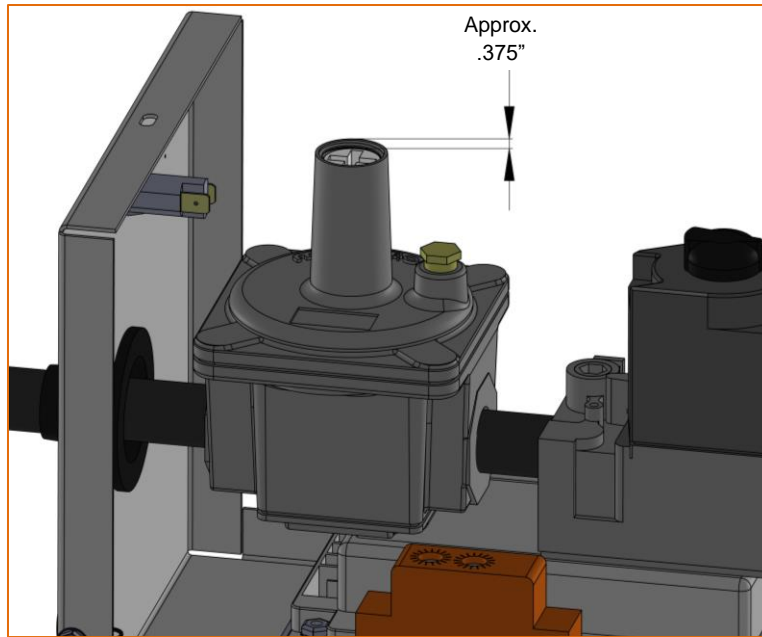

Figure 44: Adjustment Screw Starting Position

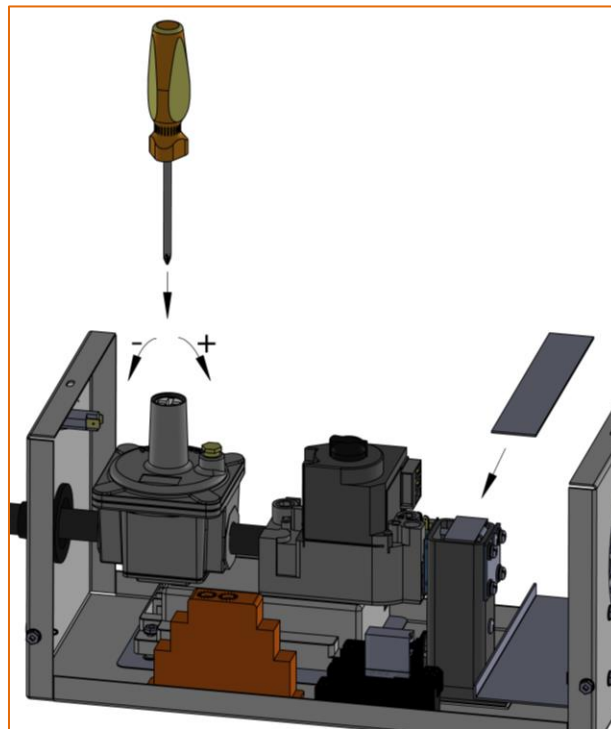

Figure 45: Adjustment of Maxitrol Zero Regulator

- a. Take a firm object (cardboard or metal strip) and when it starts to spark, carefully slide the object over the opening slowly reducing the air being drafted in.
- b. When the flame stabilizes keep the opening restricted that amount. If the adjustment screw was at the correct starting position you should not have to restrict a big amount of the opening.
- c. Adjust the Zero Regulator adjustment screw. Clockwise increases the amount of fuel being supplied to the burner and counterclockwise will reduce fuel supply.
- d. Turn the adjustment screw a 1/4 - 1/2 turn clockwise. Wait 2 – 5 seconds to allow the diaphragm in the regulator to adjust. The flame should get stronger.

- e. Now slowly slide your object back to allow more air in. Just when the flame starts to get unstable again (flutter and intermittent sparking due to loss of flame signal) turn the adjustment screw another 1/4 – 1/2 turn clockwise.
 - f. Repeat these steps until you are able to completely remove your object and allow full air draw and a nice stable flame is present. We need to make sure this is as lean as possible.
 - g. Now that the burner is up and running, turn the adjustment screw a 1/4 turn counterclockwise. After every 1/4 turn wait 5 seconds to allow it to settle. Keep turning it a 1/4 turn at a time with the pauses in between until the flame once again becomes unstable.
 - h. Now once it starts fluttering and sparking, turn the screw a 1/2 turn clockwise. This will stabilize the flame. Now we are sure it is a strong stable flame operating at its leanest.
 - i. To make sure it is operating properly, the flame sensor should be glowing red. Leave this burner running.
5. Now go to the next burner in line moving away from the burner and repeat all steps. Make sure you adjust the dip switch settings so this one will not light at the same time as the others.

NOTE: All burners need adjustment **EXCEPT** burner #1's. Those are the burners furthest away from the vacuum pump and closest to the End Vent Cap. Burner #1's uses fresh air for secondary combustion, so it is very forgiving. The flame characteristics on this burner are also different from the rest. You will still have to set the delay-on-make timer on the burner.

Now your burners are running, wait 1/2 hour with the system heating. Now we can adjust the End Vent Vacuum to get the proper vacuum designed for your system.

6 – Final Balancing the System Vacuum

1. Turn ON the Gas Supply.
2. Turn up the Thermostat(s) to start the System and let it run (with Burners operating) for at least 30 minutes.
3. With a manometer check the vacuum at the End Vent Cap of the longest Branch. (Refer to Figure 42 for manometer positioning details.)
4. Adjust the Dampers again (**Caution: dampers are now hot, adjust with caution**) as required to obtain the vacuum readings within +0.25 to -0.50 mbar of the settings in Table F. The Burners in this Branch should now be firing at the appropriate rate.
5. Proceed similarly until each individual Branch in the System is balanced/re-adjusted.
6. Mark the Damper position and lock in place when the System has been balanced. (Lock in place by putting a screw through the handle to hold it against the Sleeve/Tube.)
7. Turn the Thermostat(s) down again to shut off the System.

NOTE: An End Vent Vacuum which is intermediate to (between) those shown will result in rates intermediate and proportional to those which are listed.

NOTE: Vacuum settings and rates apply regardless of the number of Burners being used in the system branch to the maximum allowable number of burners as per Table F.

OPERATION

Manual Set-Up

1. Set the ambient temperature to be maintained by each Thermostat.
2. Ensure Electrical Power and Gas Supply are turned "ON".

Automatic Operating Sequence

Start-up

1. Thermostat calls for heat and energizes the motor start relay.
2. Motor start relay contacts close, and the Vacuum Pump motor is energized.
3. If the Vacuum Switch finds no fault, power is supplied to all the Burners in the Zone(s) in which the Thermostat(s) are calling for heat.
4. At the Burner, the control module waits for the pre-purge period and then opens the fuel valve and the spark igniter is energized. Time delay in the control module causes the Burners to light sequentially.
5. When the flame is established, the flame sensor signal returns to the control module and the ignition spark ceases.
6. If the flame is not established, the control module will re-try the ignition cycle again in 15 seconds.
7. Should ignition continue to fail, the control module will make 3 ignition attempts every hour.
8. If it does not, or if it continues to "not establish a flame", Trouble-Shoot to find the cause.
9. System operates until Thermostat(s) temperature setting is reached.

Shut down

1. When the Thermostat has been supplied sufficient heat, its contacts open and de-energize the transformer relay.
2. The contacts of the transformer relay open and Electrical Power to the Burners and Vacuum Pump is disconnected.
3. A post purge cycle can be provided when a Control Panel is supplied.
4. System remains 'OFF' until ambient temperature falls below the Thermostat(s) setting.
5. System cycles through Steps 1 to 9 on a continuous basis until Power is turned OFF.

MAINTENANCE

General Safety Reminders

- Ensure Gas Supply and Electrical Power are shut OFF before commencing maintenance work. *Exception: Checking ignitor flames will require the system to be operational.*
- Keep area clear and free from combustible materials, gasoline and other flammable vapors and liquids.
- **Caution:** Label all wires prior to disconnection when servicing controls. Wiring Errors can cause improper and dangerous operation.
- **Verify proper operation and set-up (as listed in the Commissioning section) after servicing.**

Annual Maintenance Recommendations

Annual maintenance, **prior to** the heating season (Fall/Winter) is recommended.

The System

1. Inspect the Common Tailpipe and Vent Pipe for soot or dirt, clean as required to avoid obstructions.
2. Check that Flexible Boot Connectors are without cracks, kinks or leaking connections. Change the Connectors every three to four years.
3. Ensure that the Vacuum Pump and motor mounting bolts are tight.
4. Make a visual inspection (without dismounting) of the Vacuum Pump impeller.
5. Inspect the Vacuum Switch connections.
6. Clean the Condensate Trap and ensure that all piping to/from the Condensate Trap allows free flow of fluid.
7. Make spot checks of the interior of the Radiant Line Tubes for soot or obstructions, clean as required.
8. Re-align reflectors and supports as needed.

Each Burner

1. Remove Burner and inspect burner face for soot or cracks. Burner face should be back flushed with air every year, to clean the internal ceramic burner.
2. Visually inspect electrode. Replace if there is excessive oxidation, erosion or cracks in the ceramic insulators. Set spark gap at 0.125" (3.2 mm) and clean the electrodes.
3. Verify that flame observation glass is clean, free of cracks and airtight.
4. Inspect air filter. Change as necessary – frequency is dependent on the environment.

NOTE: Dirty air filters will restrict combustion air flow into the burner housing, creating a negative pressure environment for the zero governor (and other controls). Consequently, while flame characteristics and balance will not change appreciably, overall burner rate will decline. Very dirty filters will cause the flame to become more rich (yellow and soft). Filters can be cleaned once with reverse air pressure, but it is generally more cost effective to replace them.

- Air Filter includes frame (Bulk Qty. 20) use part No. VH001B
- Filter Media Kits (Bulk Qty 24) use part No. VH053B

Adjust the System

1. Turn on gas and electric power.
2. Start system and allow to run for 30 minutes.
3. Verify end plate vacuum settings against Installation/Operation Manual, to establish correct burner rates with a manometer. Check the vacuum at the End Vent Cap of the longest Branch. (Refer to Figure 42 for manometer positioning details.)
 - If the Vacuum is too low, inspect the Flexible Boot Connectors on the Inlet and Outlet of the Vacuum Pump for tight connections, leaks, damage, kinks, etc.
 - To adjust the vacuum on a single leg, manipulate the damper coupling at the end of that leg.
 - To adjust the vacuum on the entire system, manipulate the damper coupling at the vacuum pump.
4. There should be no sound of leaking air around any of the various gaskets or connections.

Burner Adjustment

1. Observe each flame through the flame sight glass.
 - Flame may flutter once or twice at ignition but should settle promptly.
 - Flame should extend straight out from Ignitor.
 - Sense rod (and ignitor) will glow bright red/orange.
2. End burners (No. 1, or the furthest upstream from vacuum pump) do not need to be adjusted. The flame in a No. 1 burner, appears soft and fluffy, it is solid blue in colour.
3. All downstream burners (Nos. 2 - 4) may require adjustment of the Maxitrol regulator located inside each CV burner; refer to Burner Adjustment under Commissioning Chapter.
4. CV systems with multiple in-series burners can occasionally produce a high-pitched noise that can be best be described as a whistle, or howl. Usually the howl is produced by a rich no. 2 burner. De-tune the burner by slowly reducing the gas pressure at the internal Maxitrol regulator in the burner. You may also have to de-tune the no. 3 burner. Turn down the pressure till the noise disappears. Reducing it too much may cause ignition problems later.

Vacuum Pump

Vacuum Pump Fails to Run

1. Check that a Thermostat is calling for heat.
2. Check the main Electrical Power Supply, fuses or breakers.
3. Check for power to the Control Panel or Relay.

Vacuum Pump Runs, But Little to No Vacuum

1. Check the direction of the impeller rotation.
2. Are the End Vent Caps installed in all the Branches?

Vacuum Pump Runs, But No Power to Burners

1. Check the Vacuum Switch.
2. Check voltage to Burner terminals.
3. Check Relay.
4. Check individual Burner control.

Burners

No Power to Burner

1. Check if correct Thermostat is calling for heat.
2. Check for 230VAC supply at Burner.

No Gas Supply

1. Ensure manual supply valve to the System is turned ON.
2. Ensure gas valve knob on Burner gas control is ON.
3. Check for 230V across valve terminals during ignition trial time.

Burner Does Not Light

1. Ensure spark is present during ignition trial.
2. (If no, check control module, check for cracked ignitor insulation.)
3. Ensure there is gas flow during ignition trial.
4. Purge gas lines.
5. Ensure Filter is not obstructed.

Burner Does Not Stay Lit

1. Check ground wire from ignitor for continuity.
2. Measure flame signal current, it should be above 0.1uA - DC.
3. Regulator adjustment may be necessary.
4. Ensure Filter is not obstructed.

PARTS

Table G: Burner Parts List

Item No.	Part No.	Description
1	RP-VG010	ZERO GOVERNOR, MAXITROL R-500Z
2	RP-SG071	GAS VALVE, SIT Sigma 840
3	RP-VH002	VALVE GASKET
4	(See Table K)	AIR PLATE
5	RP-VS022	COMBUSTION AIR ADAPTOR & GASKET (AIR)
6	RP-VH001	COMBUSTION AIR FILTER
7	VG001	MIXING CHAMBER
8	RP-CH007	VALVE TRAIN GASKET/BURNER MOUNT
9	RP-VE147	DELAY-ON-MAKE TIMER
10	RP-CE295	CONTROL MODULE, CNE
11	RP-UE014	OPERATOR INDICATOR LIGHT (ROUND)
12	RP-VH003	GASKET, CASTING MOUNT TO TUBE
13	RP-VH058	MOUNTING U-BOLTS
14	RP-CE036	SENSE WIRE
15	RP-CE006	IGNITION WIRE
16	RP-VE002	ELECTRODE w/ SCREWS
17	RP-VH005	ELECTRODE GASKET
18	RP-CH011	FLAME SIGHT WINDOW
19	RP-VG026E*	BURNER CASTING ASSY CV < 44kW
20	GG005	PIPE NIPPLE ADAPTOR <i>(not shown)</i>

*INCLUDES ELECTRODE & MOUNTING GASKETS

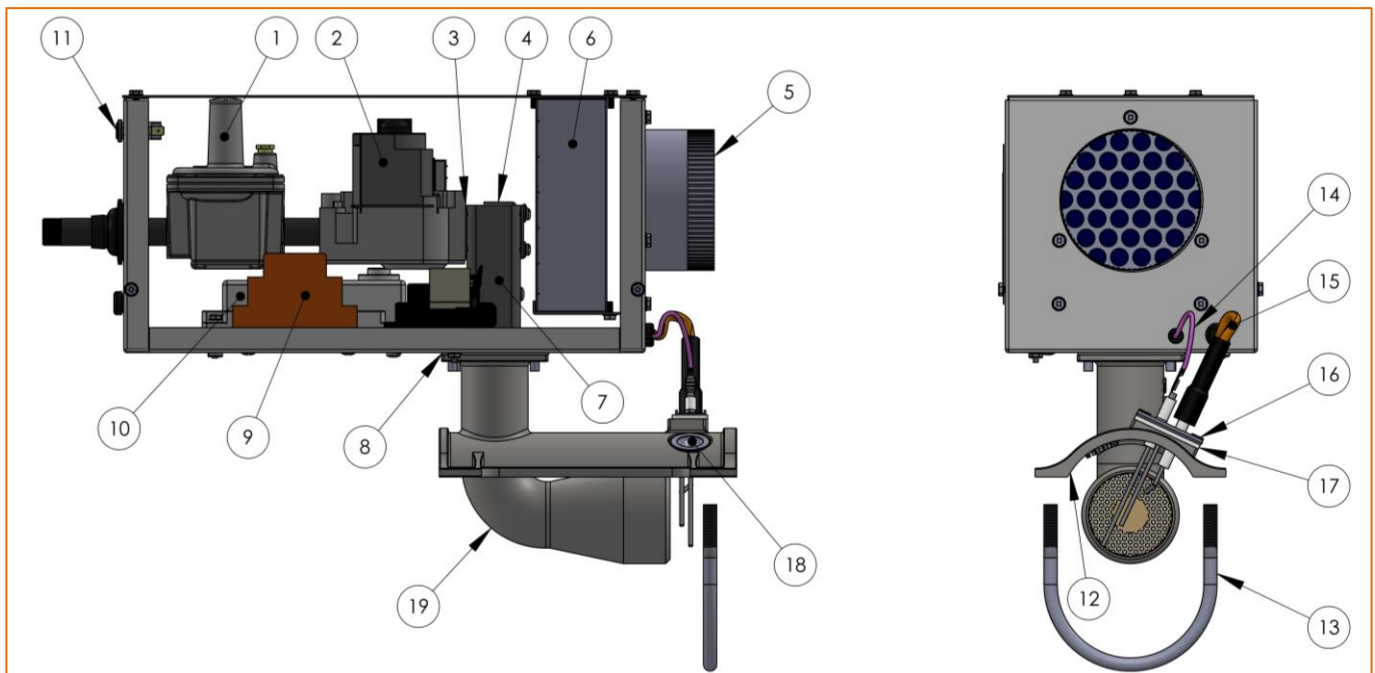

Table H: Main System Component Parts List

Part No.	Description	Part No.	Description
COMMON COMPONENTS		Coated Tubes	
VT001	VS-VH COMBUSTION TUBE, 4" OD	CT032	TUBE, 4" OD, COATED INSIDE ONLY
CT001	TUBE, 4" OD, HEAT TREATED ALUM.	CT033	TUBE, 4" OD, COATED IN & OUT
CT010	ELBOW, 90 DEG, 4" OD	VT004	COMBUSTION TUBE, VS-VH, COATED IN
CT020	U-TUBE, 4" OD	VT005	COMB TUBE, VS-VH, COAT IN & OUT
CR010	COUPLING ASS'Y 4" OD ALUM	CT034	ELBOW, 90 DEG, 4" OD, COATED IN
VS016	END VENT CAP	CT035	ELBOW, 90 DEG, 4" OD, COATED IN & OUT
CH010	TURNBUCKLE	CT105	TEE, 4" SINGLE SWEPT COATED INSIDE
CR003	HANGER, TUBE & REFLECTOR	CT107	TEE, 4" DOUBLE SWEPT COATED INSIDE
CR024	REFL. BRACKET & CLIP SET	CT106	TEE, 4" SINGLE SWEPT COATED IN/OUT
CR001	REFLECTOR 124"	CT108	TEE, 4" DOUBLE SWEPT COATED IN/OUT
CR002	END CAP	5" Tailpipe	
CS005	4" AIR INLET HOOD	CT038	TUBE, 5" OD
CR015	DAMPER COUPLING, 4" OD, MANUAL	CT040	ELBOW, 90 DEG, 5" OD
CR025	HANGER STRAP, 4" OD, TAILPIPE	CT110	ELBOW, 45 DEG, 5" OD
VH044	CONDENSATE TRAP ASS'Y	CT052	TEE, 5" OD, SINGLE SWEPT
SPECIALTY TUBING COMPONENTS		CT039	TEE, 5" OD, DOUBLE SWEPT
CT002	TUBE, 4" OD, HR	CT078	CROSS, 5" OD, DOUBLE SWEPT
CT012	TUBE, 4" OD ALUM NHT	CR068	COUPLING ASS'Y 5" OD
VT001S	SHORT COMBUSTION TUBE, VS-VH	CR070	DAMPER COUPLING, 5" OD, MANUAL
CT055	ELBOW, 45 DEG, 4" OD	CR029	HANGER STRAP, 5" OD, TAILPIPE
CT050	TEE, 4" OD, DOUBLE SWEPT	CT042	REDUCER, 5" TO 4" OD, ALUM
CT051	TEE, 4" OD, SINGLE SWEPT	6" Tailpipe	
CT109	CROSS, 4" OD, DOUBLE SWEPT	CT145	TUBE, 6" OD
Stainless Steel (S/S)		CT147	ELBOW, 90 DEG, 6" OD
VT003	S/S COMBUSTION TUBE VS-VH, 4" OD	CT152	ELBOW, 45 DEG, 6" OD
CT030	S/S RADIANT TUBE, 4" OD	CT149	TEE, 6" OD, SINGLE SWEPT
CR005	S/S COUPLING ASS'Y, 4" OD	CT146	TEE, 6" OD, DOUBLE SWEPT
CR027	S/S COUPLING LINER	CT150	CROSS, 6" OD, DOUBLE SWEPT
CR047	S/S DAMPER COUPLING, 4" OD, MANUAL	CR166	COUPLING ASS'Y 6" OD
CR032	S/S REFLECTOR, 124"	CR170	HANGER STRAP, 6" OD, TAILPIPE
CR033	S/S SIDE REFLECTOR	VT006	REDUCER, 6" TO 4" OD, ALUM
		CT151	REUDCER, 6" TO 5" OD, ALUM

Table I: Vacuum Pump and Optional Equipment Parts List

Part No.	Description	Part No.	Description
VACUUM PUMPS		GAS CONNECTION	
VH010	PUMP MOUNTING PKG.	CG012	GAS FLEX CONNECTOR - 24" x 1/2" dia.
VS010	VIBRATION BOOT PKG - 4" for vacuum pump	OPTIONAL EQUIPMENT	
VS048	VIBRATION BOOT PKG - 6" for vacuum pump	Miter Reflector Components	
VE135	VACUUM PUMP EAA w/ below:	CR039	REFLECTOR KIT, MITERED, 90 DEG
VE141	MOTOR - 0.5 HP, 208/230/460 V, 3 PH	VR003	BURNER REFLECTOR KIT
VE136	VACUUM PUMP EA w/ below:	Side Reflector Components	
VE039	MOTOR - 0.75 HP, 230/460 V, 3 PH	CR019	SIDE REFLECTOR"
VE137	VACUUM PUMP EB w/ below:	CR016	BRACKET ASS'Y, SIDE SHIELD
VE030	MOTOR - 1.50 HP, 208/230/460 V, 3 PH	CR035	RETAINER CLIP, SIDE SHIELD
PUMP ADAPTOR KITS		Bottom Shield Components	
CT155	4" TO 6" PUMP ADAPTOR KIT w/ below:	CR018	BOTTOM SHIELD
CT048	REDUCER W/ PS NIPPLE, 6" TO 4" OD	CR017	SUPPORT ASS'Y, BOTTOM SHIELD
CR046	CLAMP, 4" OD	DECO-GRILLE Components (Suspended Heater)	
CT156	5" TO 6" PUMP ADAPTOR KIT w/ below:	CR051	DECO-GRILLE, 15" x 60" x 0.5"
CT041	REDUCER W/ PS NIPPLE, 6" TO 5" OD	CR052	DECO-GRILLE SUPPORT, 60"
CR068	CLAMP, 5" OD	CR053	DECO-GRILLE CROSS STRAP, 15"
CT157	6" TO 6" PUMP ADAPTOR KIT w/ below:	CR054	DECO-GRILL END ANGLE, 15"
CT148	CONNECTOR W/ PS NIPPLE, 6" OD	DECO-GRILLE Components (Suspended Ceiling)	
CR166	CLAMP, 6" OD	CR026	DECO-GRILLE PANEL, 24" x 48"
CT158	4" TO 5" PUMP ADAPTOR KIT w/ below:	CS059	DECO-GRILLE SIDE SHIELD
CT153	REDUCER W/ PS NIPPLE, 5" TO 4" OD	CR053	DECO-GRILLE CROSS STRAP. 15"
CT046	CLAMP, 4" OD	CR054	DECO-GRILLE END ANGLE, 15"
CT159	5" TO 5" PUMP ADAPTOR KIT w/ below:	CS027	T-BAR SHIELD
CT154	CONNECTOR W/ PS NIPPLE, 5" OD		
CR068	CLAMP, 5" OD		
WALL VENT TERMINAL			
CT011	VENT TERMINAL 4" - Exterior Wall Flue (Pump EA)		
CT044	VENT TERMINAL 6" - Exterior Wall Flue (Pump EB)		
CS006	WALL THIMBLE 4" (Pump EA)		
CS033	WALL THIMBLE 6" (Pump EB)		

Table J: Burner Part Numbers

Part No.	Description	Part No.	Description
CV35N1	CV 35 BURNER #1 NAT	CV23N1	CV 23 BURNER #1 NAT
CV35N2	CV 35 BURNER #2 NAT	CV23N2	CV 23 BURNER #2 NAT
CV35N3	CV 35 BURNER #3 NAT	CV23N3	CV 23 BURNER #3 NAT
CV32N1	CV 32 BURNER #1 NAT	CV23N4	CV 23 BURNER #4 NAT
CV32N2	CV 32 BURNER #2 NAT	CV18N1	CV 18 BURNER #1 NAT
CV32N3	CV 32 BURNER #3 NAT	CV18N2	CV 18 BURNER #2 NAT
CV29N1	CV 29 BURNER #1 NAT	CV18N3	CV 18 BURNER #3 NAT
CV29N2	CV 29 BURNER #2 NAT	CV18N4	CV 18 BURNER #4 NAT
CV29N3	CV 29 BURNER #3 NAT	CV12N1	CV 12 BURNER #1 NAT
CV29N4	CV 29 BURNER #4 NAT	CV12N2	CV 12 BURNER #2 NAT
		CV12N3	CV 12 BURNER #3 NAT
		CV12N4	CV 12 BURNER #4 NAT

Table K: Burner Set-up – Install the Required Air Plate in the Correct Burner

Burner Model No.	Branch Set Up			
	Burner Air Plate (Part No.) Required for Each Position			
	Position 1	Position 2	Position 3	Position 4
CV 35	VS104	VS105	VS106	-
CV 32	VS104	VS105	VS106	-
CV 29	VS100	VS100	VS102	VS103
CV 23	VS096	VS097	VS098	VS099
CV 18	VS092	VS093	VS094	VS095
CV 12	VS088	VS089	VS090	VS091

Table L: Component Weights

Description	Weight (kg)
CV BURNER	11
TUBE, 4" OD	12
TUBE, 5" OD	15.5
TUBE, 6" OD	19
VACUUM PUMP EAA w/ below:	38
VACUUM PUMP EA w/ below:	38
VACUUM PUMP EB w/ below:	52

TECHNICAL DETAILS

	Burner Position 1	Burner Position 2	Burner Position 3	Burner Position 4	Total per branch	Branch End Vent Vacuum	Burner Injector
	kW	kW	kW	kW	kW	mbar	# mm
CV 35	35	35	35		105	8.0	K 7.14
	35	35			70		
CV 32	32	32	32		96	7.0	K 7.14
	32	32			64		
CV 29	29	29	29	29	116	7.0	1 5.79
	29	29	29		87		
CV 23	23	23	23	23	92	7.0	13 4.70
	23	23	23		69		
CV 18	18	18	18	18	72	7.0	27 3.66
	18	18	18		54		
CV 12	12	12	12	12	48	7.0	31 3.05
	12	12	12		36		

TECHNICAL DETAILS – ErP Directive

Model

CV 12

CV 18

CV 23

CV 29

CV 32

CV 35

Natural Gas

Heat Input (Net) (per branch)	P_{nom}	kW	43	65	83	104	86	95
	P_{min}	kW	25	38	51	63	52	57
Heat Input (Gross) (per branch)	P_{nom}	kW	48	72	92	116	96	105
	P_{min}	kW	28	42	56	70	58	63
Useful Efficiency (GCV)	$\eta_{th, nom}$	%	82.5	82.5	82.5	82.5	82.5	82.5
	$\eta_{th, min}$	%	86.0	86.0	86.0	86.0	86.0	86.0
Radiant Factor	RF_{nom}	%	60.3	60.3	60.3	60.3	60.3	60.3
	RF_{min}	%	63.3	63.3	63.3	63.3	63.3	63.3
Envelope Loss Factor	F_{env}	%	n/a	n/a	n/a	n/a	n/a	n/a
Control type	Modulation							
Electrical Power Consumption	el_{max}	kW	0.014	0.014	0.014	0.014	0.014	0.014
	el_{min}	kW	0.014	0.014	0.014	0.014	0.014	0.014
	el_{sb}	kW	0.00	0.00	0.00	0.00	0.00	0.00
Ignition losses	P_{pilot}	kW	n/a	n/a	n/a	n/a	n/a	n/a
NOx seasonal (gross)		(mg/kWh)	65	65	65	65	65	65
Seasonal Space Heating Energy Efficiency	η_s	%	90.1	90.1	90.1	90.1	90.1	90.1

WARRANTY

PREMIER CV VACUUM SERIES INFRARED SYSTEM

The Manufacturer warrants to the original owner that the product will be free of defects in material and workmanship as described below.

CV Vacuum System Components	Warranty Period (Years)				
	1	3	5	7	10
Control Panel	x				
Vacuum Pump		x			
Burner Electrical Components		x			
Cast Iron Burner Head					x
Hot Rolled Heat Exchanger			x		
Aluminized Heat Exchanger				x	
Hot Rolled Heat Exchanger with Control Panel				x	
Aluminized Heat Exchanger with Control Panel					x
Tailpipe – Aluminized/Coated (per minimum design length)					x

The Manufacturer's obligation under this warranty is limited to repair or replacement, F.O.B. its facility, of the defective part. In the case of replacement parts, the warranty period shall be the longer of the original warranty or a period of 12 months from date of purchase. In no event shall the manufacturer be liable for incidental expense or consequential damages of any kind.

This warranty does not cover any shipping, installation or other labour costs incurred in the repair or replacement of the product. No materials will be accepted for return without authorization.

This warranty will not apply, if in the judgment of the Manufacturer, the equipment has been improperly installed, unreasonably used, damaged, or modified.

This warranty will not apply to damage to the product when used in corrosive atmospheres and in particular atmospheres containing halogenated hydrocarbons. No person is authorized to assume for the Manufacturer any other warranty, obligation or liability.

THE REMEDIES PROVIDED FOR IN THE ABOVE EXPRESS WARRANTIES ARE THE SOLE AND EXCLUSIVE REMEDIES. NO OTHER EXPRESS OR IMPLIED WARRANTIES ARE MADE INCLUDING, BUT NOT LIMITED TO, ANY IMPLIED WARRANTY OF MERCHANTABILITY OR FITNESS FOR A PARTICULAR USE OR PURPOSE.