

ARX

ERP 
Energy related product
2021



New Ultracondens® gas heater with atmospheric burner and condensing exchanger

YAHTEC Gas Air Heater - ARX serie is an ultracondens gas heater which has the best performances of the market. With its high efficiency of 104% at full power and its low NOx emissions, the ARX complies with the new ERP2021 and allows significant energy savings and ensure heating confort into the building.

TYPICAL APPLICATION



Industries



Supermarkets



Sport facilities



Warehouses



Workshops



Greenhouses

Condensing Gas Air Heater

ARX Condensing Gas Heater is running with natural gas (G20/G25) or propane gas (G31). The range includes 5 models from 15 to 80 kW and 1 version : axial for direct blowing (ARXH).

Product advantages	Customer benefits
104% efficiency at full power	Best performances of the market
2-stages gas valve (100% - 55%)	Good warm air distribution
Robust tubular heat exchanger	Reliable and long life service unit
Pilote wire system with display	Easy control system
Automatic security system	Safe use with maintenance support
Plastic flue pipes	Economic and easy to adjust

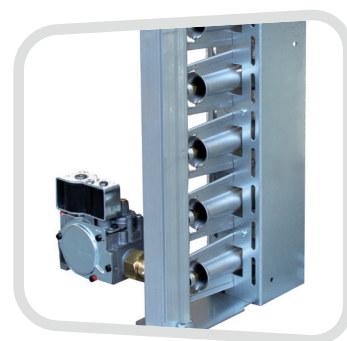

[Multi-jet gas burner]



[Condensing Heat exchanger]



[Pilote wire card]



[Axial fan]

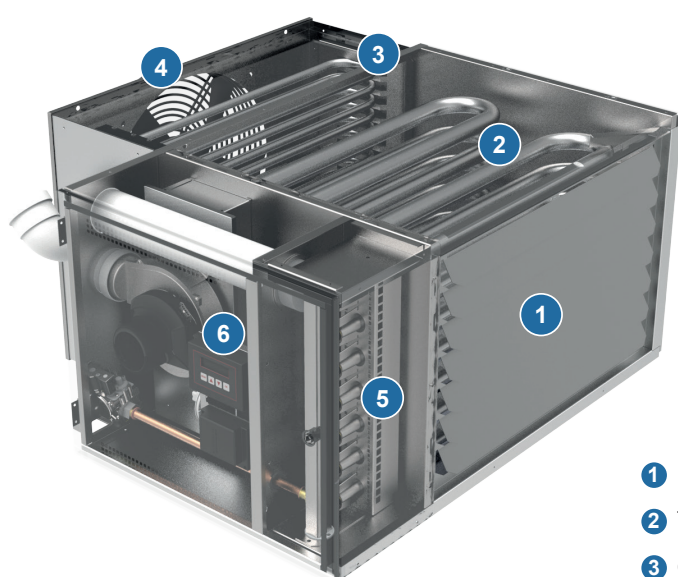

- 1 Louvers
- 2 Tubular Heat exchanger
- 3 Condensing heat exchanger
- 4 Axial fan
- 5 Atmospheric gas burner
- 6 Pilote wire card

ARXH



Performances

Models	ARX25H	ARX35H	ARX45H	ARX60H	ARX80H
Heat Input LCV (kW)	26	36	46	61	79
Nominal Output (kW)	27	38	48	64	82
Thermal efficiency (%)	104	104	104	104	103
Minimal output (kW)	15	19	27	36	47
Thermal efficiency (%)	107	107	107	107	106
Air flow T 15°C (m ³ /h)	3 320	5 000	5 400	7 200	7 800
Seasonal efficiency above 88% - NO _x lower than 70 mg/kWh					

Dimensions

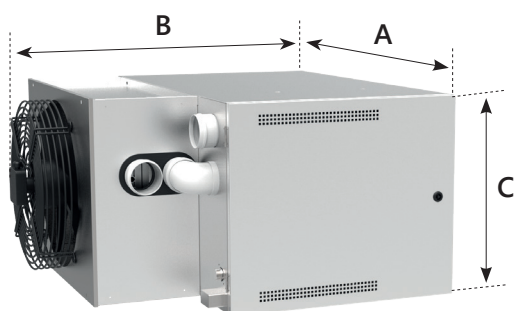

Models	ARX25H	ARX35H	ARX45H	ARX60H	ARX80H
A (mm)	1 060	1 060	1 060	1 060	1 060
B* (mm)	1 110	1 110	1 110	1 110	1 110
C (mm)	495	545	560	710	912
Gas (mm)	3/4"	3/4"	3/4"	3/4"	3/4"
Fumes (mm)	80	80	80	80	100
Air (mm)	80	80	80	80	100
Weight (kg)	98	121	133	160	203

* From the front to back side of gas heater

Flue connection

